

Model 3510/3511 "MIDGIT" 3 1/2 DIGIT DIN 24x48 TEMPERATURE INDICATORS



Processing your future →



The Model 3510 is a 3½ digit (1999) LED Temperature Indicator and is used in mimic panels for accurate display of temperature from PT100 RTD probes.

The Model 3511 is a 3½ digit (1999) LED Temperature Indicator and is used in mimic panels for accurate display of temperature from thermocouple probes.

Both models obtain high accuracy and repeatability through multipoint linearisation of the input signals. Integral cold junction compensation is included in the thermocouple model.

FEATURES

- ❑ DIN 24 X 48 enclosure
- ❑ 1999 Counts
- ❑ 7,5 mm Red LED display
- ❑ Very low power consumption (35 mA typical)
- ❑ Broken thermocouple protection on Model 3511
- ❑ Multipoint linearisation for high accuracy

OPTIONS

1008 Galvanically isolated DC supply

POWER SUPPLY

8 - 12 V DC	
24 V DC	± 10%
12 V DC	± 10% galvanically isolated (option)
24 V DC	± 10% galvanically isolated (option)

SPECIFICATIONS

Settling time	: 1 second
Operating temperature range	: 0 to +55°C
Storage temperature range	: -40 to 85°C
Warmup time	: 10 minutes
Temperature Coeff.	: ± 30 ppm /°C typ.

RANGES & CONNECTIONS

RANGES

Model 3510 (PT100 input) standard measuring range :

Code	Range	Accuracy	Resolution
HR	-150 to +450 °C	1 °C	1 °C
LR	-50.0 to +199.9 °C	0.3 °C	0.1 °C

Model 3511 (Thermocouple input) standard measuring range (specify thermocouple type on order) :

Code	Range	Accuracy	Resolution	Extended Range (Note 1)
Type J	0°C to +650°C	1 °C	1 °C	-25 to +750 °C
Type K	0°C to +1250°C	1 °C	1 °C	-40 to +1350 °C
Type R	+750°C to +1750°C	1 °C	1 °C	+650 to +1800 °C
Type S	+1000°C to +1750°C	1 °C	1 °C	+950 to +1800 °C
Type W5	+1200°C to +1999°C	1 °C	1 °C	+1150 to +1999 °C
Type T+	+20°C to +300°C	1 °C	1 °C	-30 to +350 °C
Type T-	-230°C to +25°C	1 °C	1 °C	-250 to +40 °C

Note 1: With derated accuracy

ORDERING E.G.

Model 3511 - 24 V DC - Type J

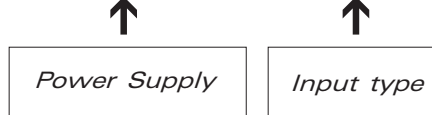

CONNECTIONS

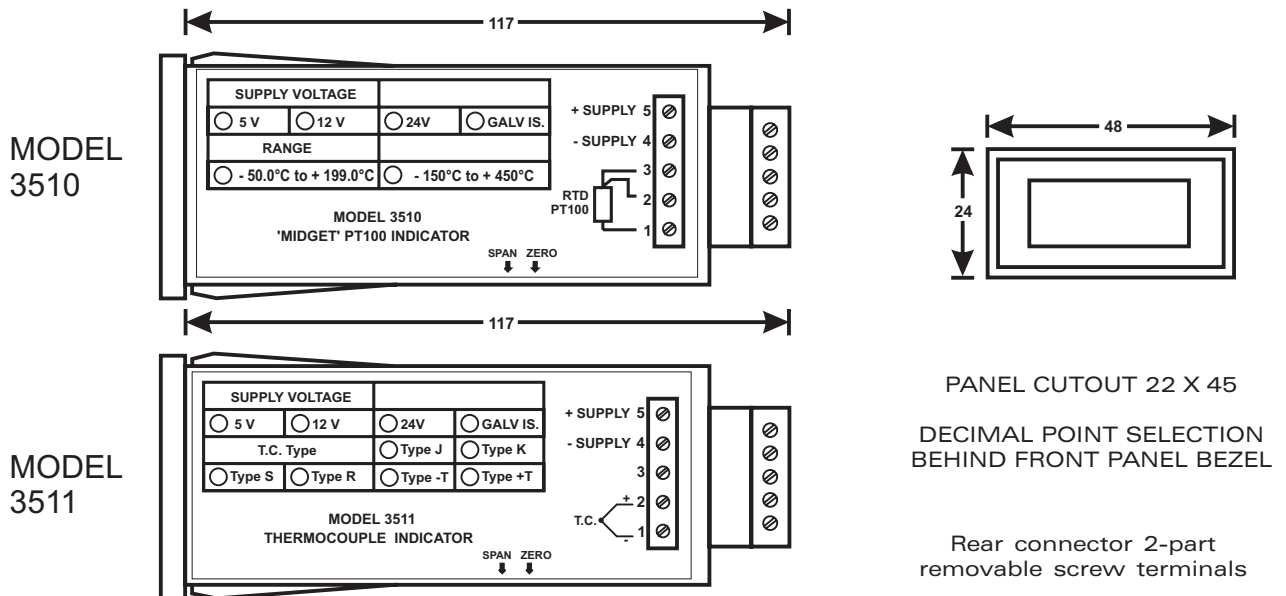

GUARANTEE

This product is guaranteed against faulty workmanship or defective material, for a period of 3 (three) years from date of delivery by DPM.

DPM undertakes to replace without charge all defective equipment which is returned to it (transportation costs prepaid) during the period of guarantee, provided there is no evidence that the equipment has been abused or mishandled in any way.

DPM reserves the right to alter any specification without notice.

e-mail : stephane@dpm.co.za
 Web: <http://www.dpm.co.za>

DISTRIBUTED BY:

