

# Option 3016

## Power Booster for up to 6 load cells

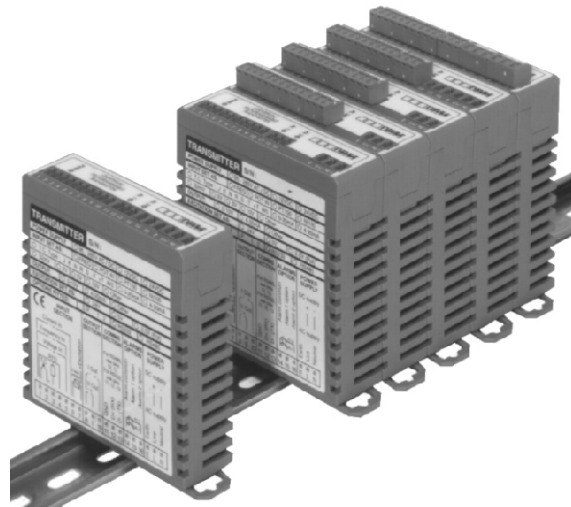

Processing your future



The Option 3016 is a small DIN-rail mount power booster to provide excitation for up to 6 load cells. This unit interfaces to DPM's load cell indicators Model 4004 & Model 5004. This product meets European Community EMC directive 89/336/EEC & Low Voltage Directive 73/23/EEC.

### Features

- ❑ Small DIN-rail mount 92 x 92 x 26 mm
- ❑ Provides excitation for up to 6 load cells

### Power Supply

Standard power supply 95-265V AC/DC

### Housing

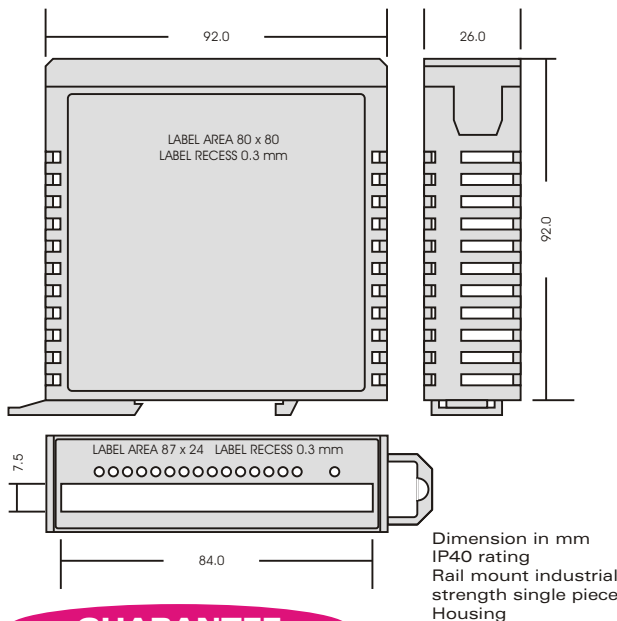

### Connections

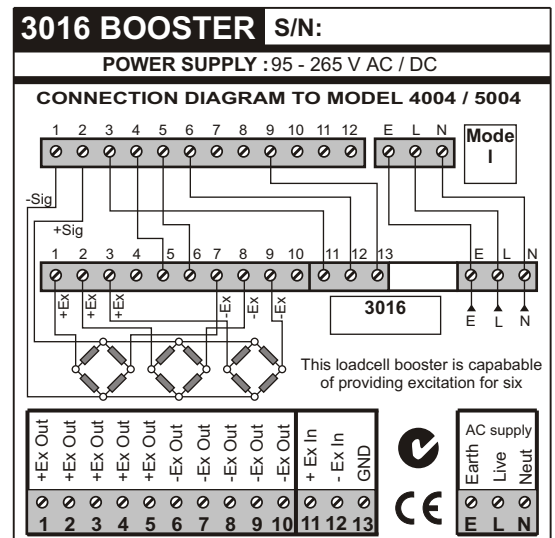

### GUARANTEE

This product is guaranteed against faulty workmanship or defective material, for a period of 3 (three) years from date of delivery by DPM. DPM undertakes to repair without charge all defective equipment which is returned to it (transportation costs prepaid) during the period of guarantee, provided there is no evidence that the equipment has been abused or mishandled in any way.

DPM reserves the right to alter any specification without notice.

E-mail : [stephane@dpm.co.za](mailto:stephane@dpm.co.za)  
Website : [www.dpm.co.za](http://www.dpm.co.za)

### DISTRIBUTED BY: