

# Voltage Dip-Proofing Inverter

**DPI54S / 54L Series Models  
120V & 208/230 50/60Hz**

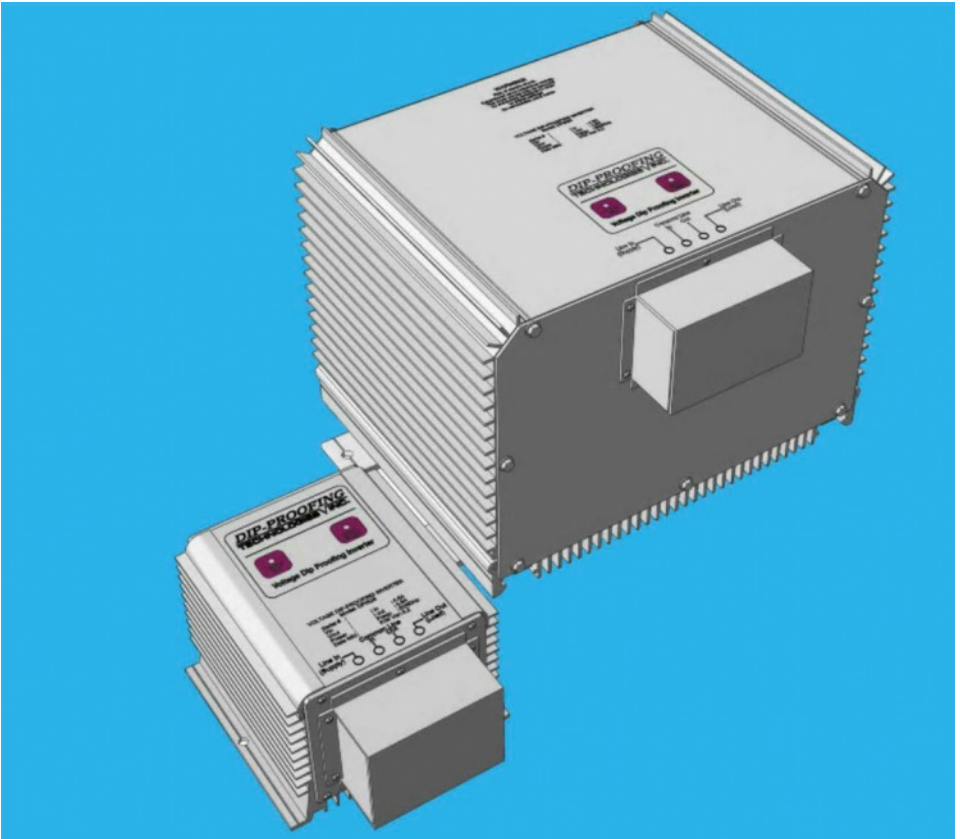

***DIP-PROOFING***  
**TECHNOLOGIES *V* INC.**  
LEADERS IN VOLTAGE-DIP PROOFING



# ***Installation & Service Manual***

---

**Contents:**

Introduction.....3

Theory of operation .....3

Specifications .....5

Up-time considerations .....6

Installation Guide .....7

Test and Maintenance.....9

Mechanical Outline .....11

Accessories .....14

**Notice:**

**IMPORTANT SAFETY INSTRUCTIONS!  
KEEP THESE INSTRUCTIONS FOR FUTURE REFERENCE**

This manual contains important instructions that should be followed during installation and adjustment of all DPI54 Series Voltage Dip-Proofing Inverters.

## 1. Introduction

The reliability of electrical power to industry is in general very high, nevertheless, voltage sags and short power interruptions or voltage dips occur. These instabilities are caused by short circuits, lightning strikes on overhead power lines and heavy load switching. The duration of such faults is generally shorter than one second.

Most plant can ride through such voltage dips by virtue of their mechanical and electrical inertia. However, this is not the case with electrically held-in contactors and relays that control the machinery. Contactors typically drop out from 5ms to 20ms after power is removed. Each short voltage dip now becomes a power failure and the plant must be restarted. This can be complicated, time-consuming and costly.

SWITCHING SYSTEMS' VOLTAGE DIP- PROOFING INVERTERS are designed to maintain the switchgear control voltage during voltage dips, effectively keeping the plant connected. The stored electrical and magnetic energy is allowed to flow, supporting the mechanical inertia of the machinery. When the power is restored after a short voltage dip, the plant is still running at near synchronous speed, the inrush currents will be small and the stress to the system minimal.

Historically, this problem has been addressed by using DC contactors, latched contactors and intelligent controls such as PLC's. These systems are complex and expensive and do not provide a solution for equipment already in existence. The current approach to this problem has been to employ intelligent control systems which provide a curative solution. In contrast, the Voltage-Dip Proofing Inverter, provides a preventative solution.

## 2. Theory of operation

The VOLTAGE-DIP PROOFING INVERTER is designed to be maintenance free and highly reliable. It consists of a static switch in series with, and an inverter parallel to, the load. Energy is stored in a capacitor bank : the inverter block diagram is shown in Fig 1.

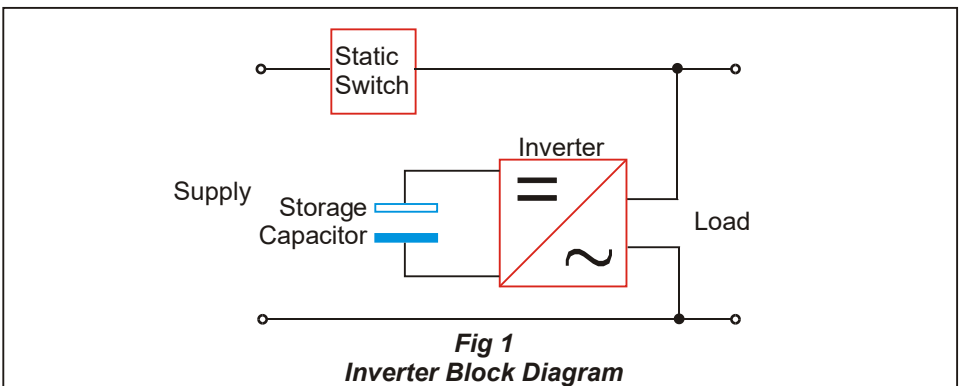

**Fig 1**  
**Inverter Block Diagram**

## ***Installation & Service Manual***

---

The STATIC SWITCH is robust and can withstand large current surges. It is ideally suited for contactor operation where high peak currents of short duration occur during energizing.

The INVERTER is configured as a full bridge with overcurrent and short circuit protection. The output waveform is a square wave where the RMS and the peak voltage are the same as for a sine wave as shown in Fig 2.

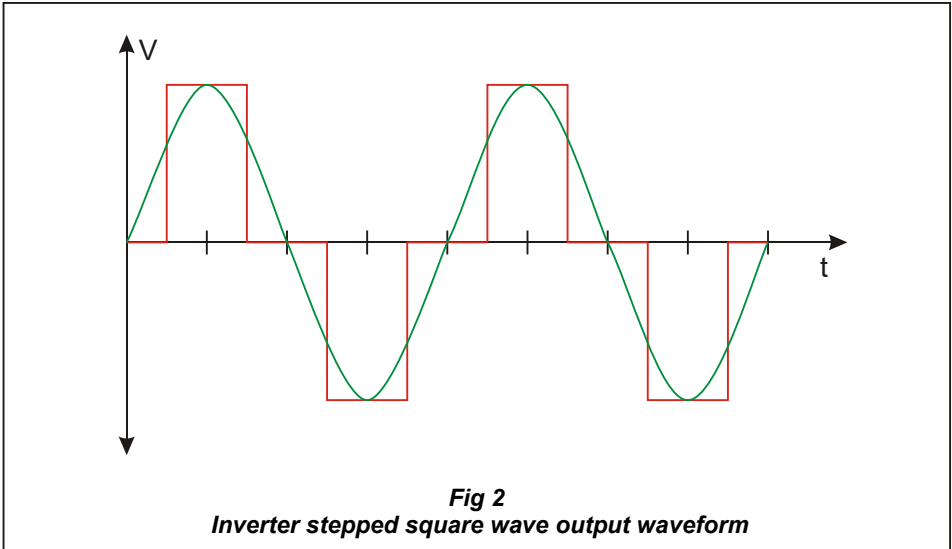

This is important for circuits where magnetic devices, such as transformers and contactors (RMS voltage) are in circuit with electronic relays that derive their DC voltage from capacitor input filters (peak voltage).

The computer grade CAPACITOR BANK operates under ideal conditions, being charged to working voltage but carrying no ripple current most of the time.

During stand-by operation, the static switch supplies power directly to the load, the inverter is switched off and the capacitors are charged to the full operating voltage. The supply voltage is constantly monitored for deviations; should there be a deviation from  $V_{nom}$  which is greater than the preset value, the static switch is switched off and the inverter is activated. The switch-over is accomplished in less than 200 $\mu$ s. A 3.15 second timer, adjustable in increments of 50ms, starts timing the inverter out. Should the input voltage recover within the set time, the inverter supply is synchronized to the mains and the load is switched back to the supply, the capacitors are recharged in less than one second and the inverter is ready to compensate for the next voltage dip. If the input voltage does not recover within the set time the load is switched back to the supply regardless of the voltage level.

Specifications DPI 54S / 54L Series 120V Models	DPI54S6.6mF120V6A	DPI54S13.2mF120V6A	DPI54S19.8mF120V6A	DPI54S39.6mF120V8A	DPI54L33mF120V25A	DPI54L66mF120V25A	DPI54L99mF120V25A	DPI54L198mF120V25A	DPI54L297mF120V25A	DPI54L396mF120V25A	DPI54L495mF120V25A	DPI54L594mF120V25A	DPI54L693mF120V25A
<b>AC INPUT SUPPLY</b>													
Single phase supply voltage							120V	50/60Hz					
Maximum input voltage							+10%						
Full load current (A)		6A		8A			25A						
<b>STATIC SWITCH</b>													
Nominal off-state voltage							150Vac	RMS					
Peak off-state voltage							800V						
Nominal current (A)		6A		8A			25A						
Short time overload current (<100ms)			30A				60A						
Non-repetitive peak on-state current (10ms)			170A				700A						
<b>INVERTER</b>													
Nominal output voltage							120Vac	RMS					
Voltage fluctuations over full operating range							±10%						
Nominal load current (A)		6A		8A			25A						
Overload Current (A)			15A				30A						
Power factor range							cosΦ	from 1 to 0					
Wave shape							Stepped square						
Nominal load (VA)			720	960			3000						
Storage capacitors (F)	.0066	.0132	.0198	.0396	.033	.066	.099	.198	.297	.396	.495	.594	.693
Usable stored energy factor (η)							0.47						
Minimum up-time as function of the load							$t = (\eta * C_{cap} * V_{supply}) / (I_{load} * \cos \Phi)$						
Output frequency							50/60Hz	±1%					
Max recovery time of capacitors to 95%Vin	0.5s	1.1s	1.6s	2.4s	0.6s	1.2s	1.8s						
<b>SETTINGS</b>													
Timer Range and Setting							0.05 - 3.15s	in 0.05s steps					
Transfer Level Range and Setting							90% to 65%	of calibrated supply voltage $V_{in}$	in 5% steps				
<b>INDICATORS</b>													
System OK							green	LED					
Inverter running							red	LED					
<b>TEMPERATURE</b>													
Maximum ambient working temperature							45°C	(113°F)					
<b>CUBICLE</b>													
Construction							Extruded Aluminum						
Height (mm)	170	205	310	284	284	284	454	544	634	724	814	904	
Height (in)	6.69	8.07	12.20	11.18	11.18	11.18	17.87	21.42	24.96	28.5	32.05	35.59	
Width (mm)		150 (5.90)				350 (13.78)							
Depth (mm)		110 (4.33)				231 (9.09)							
Mass (kg)	2.2	2.5	2.7	4.4	8.7	10	11.5	19	25	31	37	43	49
Mass (lbs)	4.8	5.4	5.9	9.6	19.1	22	25.3	41.8	55	68.2	81.4	94.6	108
<b>CONNECTION</b>													
Cable, Copper panel wire		1mm <sup>2</sup> (17AWG)				6mm <sup>2</sup> (10AWG)							
Screw terminal torque		1.76 Nm (15.6 lb-in)											

# Installation & Service Manual

Specifications DPI 54S / 54L Series 208 / 230V Models	DPI54S2.04mfF230V6A	DPI54S4.08mfF230V6A	DPI54S6.12mfF230V6A	DPI54S12.24mfF230V8A	DPI54L15mfF230V25A	DPI54L30mfF230V25A	DPI54L45mfF230V25A	DPI54L90mfF230V25A	DPI54L135mfF230V25A	DPI54L180mfF230V25A	DPI54L225mfF230V25A	DPI54L270mfF230V25A	DPI54L315mfF230V25A
<b>AC INPUT SUPPLY</b>													
Single phase supply voltage					230V 50/60Hz								
Maximum input voltage					+10%								
Full load current (A)		6A		8A			25A						
<b>STATIC SWITCH</b>													
Nominal off-state voltage					250Vac RMS								
Peak off-state voltage					800V								
Nominal current (A)		6A		8A			25A						
Short time overload current (<100ms)		30A					60A						
Non-repetitive peak on-state current (10ms)		170A					700A						
<b>INVERTER</b>													
Nominal output voltage					230Vac RMS								
Voltage fluctuations over full operating range					±10%								
Nominal load current (A)		6A		8A			25A						
Overload current (A)		15A					30A						
Power factor range					cosφ from 1 to 0								
Wave shape					Stepped square								
Nominal load (VA)		1380		1840			5750						
Storage capacitors (F)	.00204	.00408	.00612	.01224	.015	.030	.045	.090	.135	.180	.225	.270	.315
Usable stored energy factor (η)		0.53					0.55						
Minimum up-time as function of the load					$t = (\eta \cdot C_{cap} \cdot V_{supply}) / (I_{load} \cdot \cos \Phi)$								
Output frequency					50/60Hz ±1%								
Max recovery time of capacitors to 95%Vin	0.7s	1.4s	2.0s	3.0s	1.0s	2.1s	3.2s	8.0s	8.0s				
<b>SETTINGS</b>													
Timer Range and Setting					0.05 - 3.15s in 0.05s steps								
Transfer Level Range and Setting					90% to 65% of calibrated supply voltage $V_{cal}$ in 5% steps								
<b>INDICATORS</b>													
System OK					green LED								
Inverter running					red LED								
<b>TEMPERATURE</b>													
Maximum ambient working temperature					45°C (113°F)								
<b>CUBICLE</b>													
Construction					Extruded Aluminum								
Height (mm)	170	205	310	284	284	284	454	544	634	724	814	904	
Height (in)	6.69	8.07	12.20	11.18	11.18	11.18	17.87	21.42	24.96	28.5	32.05	35.59	
Width (mm)		150 (5.90)				350 (13.78)							
Depth (mm)		110 (4.33)				231 (9.09)							
Mass (kg)	2.2	2.5	2.7	4.4	8.7	10	11.5	19	25	31	37	43	49
Mass (lbs)	4.8	5.4	5.9	9.6	19.1	22	25.3	41.8	55	68.2	81.4	94.6	108
<b>CONNECTION</b>													
Cable, Copper panel wire	1mm <sup>2</sup> (17AWG)				6mm <sup>2</sup> (10AWG)								
Screw terminal torque					1.76 Nm (15.6 lb-in)								

### Up-time considerations

The up-time that a DPI can achieve is dependent on the usable energy in the storage capacitors and on the characteristics of the supported load. Load characteristics are critical in determining the up-time. Resistive loads with a power factor near 1 consume real power and the up-time will be shortest. Resistive loads include lamps, switch mode power supplies and linear power supplies. Contactors use little real power as they are a reactive load with power factors around 0.15. Reactive loads such as contactors give the longest up-time.

The formulae below can be used to determine the minimum up-time that can be achieved for an application. It uses the load current, load voltage, load power factor, the value of the DPI storage capacitors and a stored energy factor to calculate the value.

Minimum up-time as function of the load:  $t = (\eta * C_{cap} * V_{supply}) \div (I_{load} * \cos \Phi)$

Minimum up-time = t

Value of storage capacitor(s) =  $C_{cap}$

Stored energy factor =  $\eta$

Load voltage =  $V_{supply}$

Load current =  $I_{load}$

Load power factor =  $\cos \Phi$

From the formulae it can be seen that the power factor ( $\cos \Phi$ ) has a significant influence on the up-time. *Resistive* loads with  $\cos \Phi = 1$  will yield the shortest up-time while *reactive* loads with  $\cos \Phi = 0.15$  will yield the longest up-time. For example:

A. Using DPI model DPI54L15mF230V25A find the minimum up-time for a predominantly *resistive* load; say a PLC power supply and some small relays.

Value of storage capacitor(s) = 0.015F

Stored energy factor = 0.55

Load voltage = 230V

Load current = 6A

Load power factor = 0.8

Minimum up-time  $t = (0.55 * 0.015 * 230) \div (6.0 * 0.8) = \mathbf{0.39 \text{ seconds}}$ .

B. Using DPI model DPI54L15mF230V25A find the minimum up-time for a predominantly *reactive* load; say some small contactors and relays.

Value of storage capacitor(s) = 0.015F

Stored energy factor = 0.55

Load voltage = 230V

Load current = 6.0A

Load power factor = 0.15

Minimum up-time  $t = (0.55 * 0.015 * 230) \div (6.0 * 0.15) = \mathbf{2.1 \text{ seconds}}$ .

The examples illustrate the importance of knowing the load power factor when calculating the minimum up-time for a DPI application. For best accuracy use the on line DPI Selector to find the correct size DPI for an application.

Link: [http://www.dipproof.com/products/dpi\\_selector.asp](http://www.dipproof.com/products/dpi_selector.asp)

# Installation & Service Manual

## Installation Guide

1. Remove the unit from its packing
2. Place the unit horizontally on a bench and visually check for any mechanical damage. Ensure that all the casing screws are tight then shake the unit to check that there is nothing loose internally.
3. Check that the inverter voltage is the same as the system control voltage. Refer to the rating label on the unit end plate.  
**WARNING:** Never connect a 120V unit to a 230V supply!
4. Decide on the location where the unit is to be installed, this will probably be inside a switch gear panel.
5. Mount the unit vertically using M6 bolts.
6. Connect unit as shown in Fig 3 using 1mm<sup>2</sup> (17AWG) DPI54S Series & 6mm<sup>2</sup> (10AWG), DPI54L Series copper panel wire.
7. Apply terminal screw tightening torque of 1.5 - 1.8Nm (13 - 16 lb-in).
8. This device does not have a disconnect switch. If such a switch is required it must be provided by others.

## Power Wiring Connections

Line In (Supply)	to	Terminal 1
Common Line In	to	Terminal 2
Common Line Out	to	Terminal 3
Line Out (Load)	to	Terminal 4

Ground screws to be connected on the unit to the panel ground point.

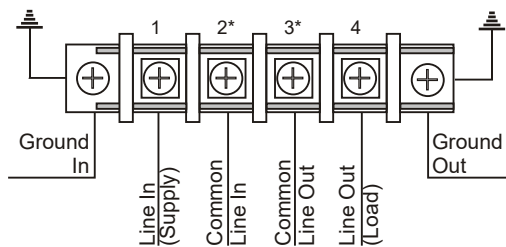

\* Note:  
Terminals 2 and 3 are linked internally

**Fig 3**  
**Power Wiring Diagram**



9. Once the unit has been mounted and the external wiring completed, power can be applied. Turn on the power to the unit. After about two seconds the green LED indicator "System OK" should come on. The unit is now fully operational.

10. In applications which require no break maintenance, a bypass switch must be installed. Order Housed Bypass Switch model DPIBPSW which should be connected as shown in Fig 4.

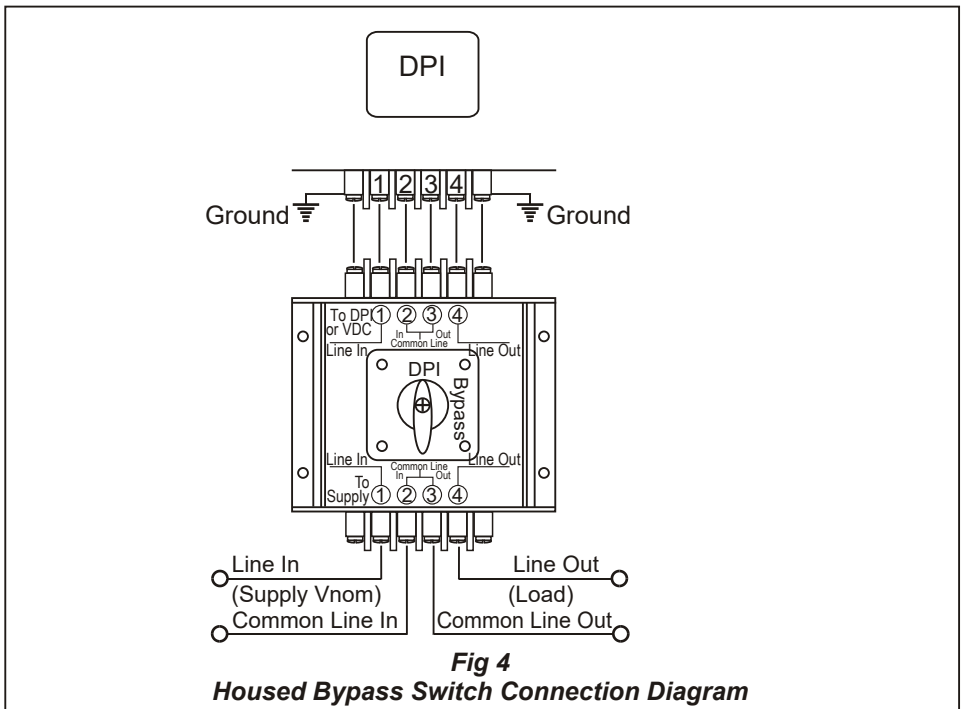

### Functional Description Indicators

**System OK** : Green LED indicator. When the green LED is ON the system is fully functional; the unit self- test and initialization routine has run successfully.

**Inverter Running** : Red LED indicator. The red LED is on when the inverter is running during a voltage dip. A stepped square wave is present on the output terminals 3 and 4.

# Installation & Service Manual

---

## Test and Maintenance

There are no user serviceable parts inside the unit, if faulty return to factory or local agent for repairs.

**WARNING:** Risk of electric shock, capacitor(s) store hazardous energy.

NEVER attempt any maintenance on the DPI until storage capacitors are fully discharged. Dangerously high voltages can be present up to 2 hours after the DPI has been disconnected unless the storage capacitors have been manually discharged.

## Adjustments

All adjustment points are marked on the top cover plate and can be reached by removing the two screws securing the main label.

### INVERTER RUN TIME - DSW3

This switch sets the running time of the inverter and can be set in 50ms steps to a maximum of 3,15 seconds. To determine the inverter run time which is currently set, add the figures printed next to each switch which is in the ON position. For example, a running time setting of one second requires that the following switches be in the ON position:- 200 + 800 : these figures added give 1000ms or 1s.

*Factory Setting : 1000ms*

### CALIBRATION TO A SUPPLY VOLTAGE - Cal

The unit can be calibrated for a different supply voltage, for example a 230V unit used on a 208V supply. The Calibrate button (Cal) is used to program the unit to operate on a specific supply voltage.

**WARNING:** Never connect a 120V unit to a 230V supply! Refer to the unit rating label before connecting the supply.

Connect the unit to the supply and switch on.

Press the Calibrate button (Cal). The System OK (green) LED will switch off for approximately 3 seconds and then switch back on.

The unit is now calibrated for the supply voltage to which it is connected.

*Factory Setting : Calibrated to rating label Vnom*

### ADJUSTMENTS - DSW1 (Factory settable ONLY)

TYPE	SWITCHES				DESCRIPTION
	1	2	3	4	
Standard	0	0	0	0	250 $\mu$ sec. detection time
Two level	1	0	0	0	<30% of nom-voltage fixed run time of 200msec
Noise immune	0	1	0	0	1msec detection time
Noise immune and Two level	0	0	1	0	both of the above

*Factory setting: Noise immune*

### TRANSFER LEVEL - DSW2

Sets the supply voltage level at which the inverter switches to run mode. The level can be varied between 65% and 90% of the nominal supply voltage by setting the switches according to the table in Fig.5.

*Factory setting : 75%*

---

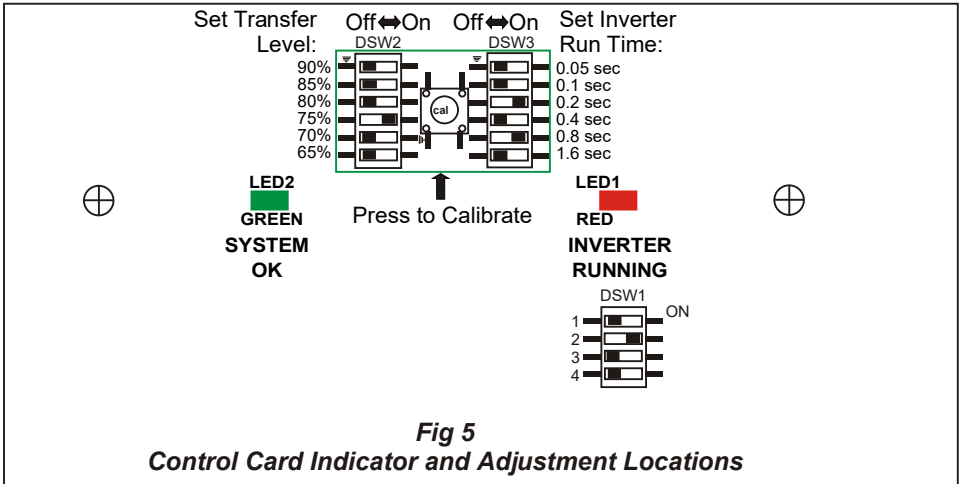

## Diagnostics

### 1. Supply Voltage Out of Range

If the unit supply voltage is permanently outside the +/- 10% range of the supply voltage to which the unit is calibrated (Vcal) the unit will not power up and there will be no LED indicators on. Recalibration to the new supply voltage is necessary.

### Diagnostic relay outputs

#### 2. Unit faulty, relay contact opens (T6 - T7) if:

- There is no power on input (T1 - T2)
- If, at power up, the supply voltage does not exceed the set transfer level
- Unit control power supply is faulty
- Microcontroller faulty
- Microcontroller watchdog activated; program execution problem
- Inverter fuse blown
- No voltage on storage capacitors
- Unit has no output voltage (T3 & T4)

### Event detection relay contact changes state (T8 - T10) when:

- The inverter runs to support an event.

**Note:** The options for diagnostic and event detection outputs should be specified when ordering.

The DPI54S Series supports the Event Detection option and Diagnostics.

# Installation & Service Manual

## Mechanical Construction

**54S Series** - The DPI case is made from extruded aluminium sections. The four parts that make up the case are interlocked and secured by screws. To remove the front cover, unscrew four screws: the two top screws from the end plate where the terminal block is located and the two bottom screws from the other end plate. Slide the front cover away from the terminal block. Note that there are no user serviceable parts inside the unit. All adjustment points are marked on the top cover plate and can be reached by removing the two screws securing the main label.

**54L Series** - The DPI case is made from extruded aluminium sections. The six parts that make up the case are interlocked and secured by screws. To remove the front cover, unscrew five screws: one from the front cover and two each from the top and bottom end plates. Units are supplied with four or six mounting brackets depending on the case length. The bracket positions are adjustable along the length of the case (Dim. L1 and L6). Note that there are no user serviceable parts inside the unit. All adjustment points are marked on the top cover plate and can be reached by removing the two screws securing the main label.

## Dimension Table

MODEL	DPI54 SERIES DIMENSIONS mm (inches)							
	L1	L2	L3	L4	L5	L6	L7	D
DPI54S6.6mF120V6A	0 (0)	170 (6.69)	219 (8.62)			85 (3.35)		
DPI54S13.2mF120V6A	0 (0)	170 (6.69)	219 (8.62)	110 (4.33)	150 (5.90)	85 (3.35)	140 (5.50)	6.0 (0.24)
DPI54S19.8mF120V6A	0 (0)	205 (8.07)	254 (10.0)			102.5(4.04)		
DPI54S39.6mF120V8A	163 (6.41)	313 (12.32)	359 (14.13)			75 (2.95)		
DPI54L33mF120V25A								
DPI54L66mF120V25A	115 (4.53)	235 (9.25)	284 (11.18)					
DPI54L99mF120V25A						60 (2.36)		
DPI54L198mF120V25A	240 (9.45)	360 (14.17)	409 (16.10)					
DPI54L297mF120V25A	331 (13.03)	451 (17.76)	500 (19.69)	231 (9.09)	350 (13.78)		330.5(13.0)	8.0 (0.31)
DPI54L396mF120V25A	422 (16.61)	542 (21.33)	591 (23.27)					
DPI54L495mF120V25A	513 (20.20)*	633 (24.92)	682 (26.85)					
DPI54L594mF120V25A	604 (23.78)*	724 (28.50)	773 (30.43)					
DPI54L693mF120V25A	695 (27.36)*	815 (32.08)	864 (34.02)					
DPI54S2.04mF230V6A	0 (0)	170 (6.69)	219 (8.62)			85 (3.35)		
DPI54S4.08mF230V6A	0 (0)	170 (6.69)	219 (8.62)	110 (4.33)	150 (5.90)	85 (3.35)	140 (5.50)	
DPI54S6.12mF230V6A	0 (0)	205 (8.07)	254 (10.0)			102.5(4.04)		6.0 (0.24)
DPI54S12.24mF2308A	163 (6.41)	313 (12.32)	359 (14.13)			75 (3.00)		
DPI54L15mF230V25A								
DPI54L30mF230V25A	115 (4.53)	235 (9.25)	284 (11.18)					
DPI54L45mF230V25A								
DPI54L90mF230V25A	240 (9.45)	360 (14.17)	409 (16.10)					
DPI54L135mF230V25A	331 (13.03)	451 (17.76)	500 (19.69)	231 (9.09)	350 (13.78)	60 (2.36)	330.5(13.0)	8.0 (0.31)
DPI54L180mF230V25A	422 (16.61)	724 (28.50)	591 (23.27)					
DPI54L225mF230V25A	513 (20.20)*	815 (32.08)	682 (26.85)					
DPI54L270mF230V25A	604 (23.78)*		773 (30.43)					
DPI54L315mF230V25A	695 (27.36)*		864 (34.02)					

\* Indicates 6 mounting brackets; dimension L1\* = L1/2

## Mechanical Outline

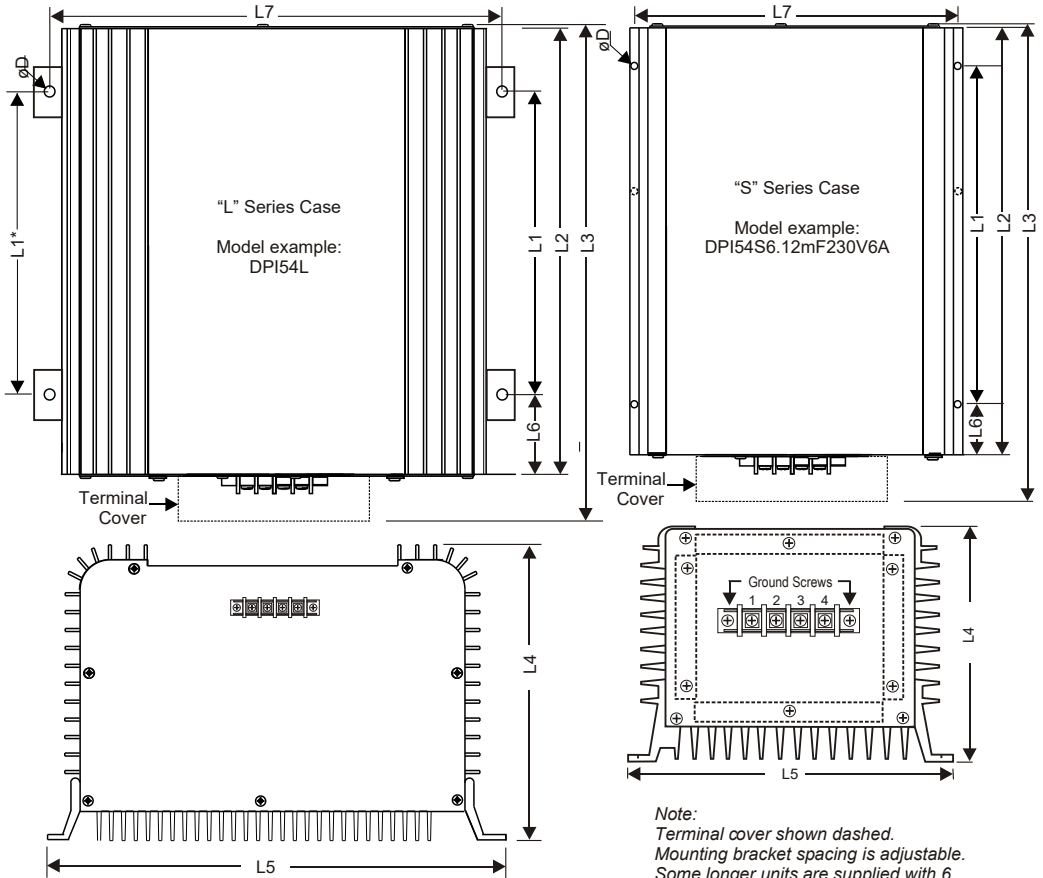

### Terminal Block for 54L Series Options



- Terminal 1 Line In (Supply)
- Terminal 2 Common line in
- Terminal 3 Common line out
- Terminal 4 Line out (Load)
- Terminal 5 Unit Faulty n/o
- Terminal 6 Unit Faulty n/o
- Terminal 7 Event detection n/o
- Terminal 8 Event detection n/o

### Terminal Block for 54S Series Options



- Terminal 1 Line In (Supply)
  - Terminal 2 Common line in out
  - Terminal 3 Line out (Load)
  - Terminal 4 Unit Faulty n/o
  - Terminal 5 Common
- OR
- Terminal 4 Event detection n/o
  - Terminal 5 Common

***Installation & Service Manual***

---

*This page left blank intentionally.*

## Accessories

### Housed Bypass Switch

Description: Where no-break maintenance is required, a bypass switch must be installed. It connects the supply directly to the load, "Bypass" position, and disconnects the power terminals of the inverter without interrupting the supply. When in "DPI" position, the load is connected to the supply via the inverter.

### SPECIFICATIONS

Model	BPSW25A
<b>ELECTRICAL</b>	
Maximum current	25A
Maximum Input Voltage	600V AC
<b>TEMPERATURE</b>	
Maximum Working Temperature	45°C (113°F)
<b>HOUSING</b>	
Construction	Extruded Aluminium
Height	202mm (7,95in)
Width	150mm (5,9in)
Depth	141mm (5,55in)
Mass	1kg (2.2lbs)

### Mechanical Outline

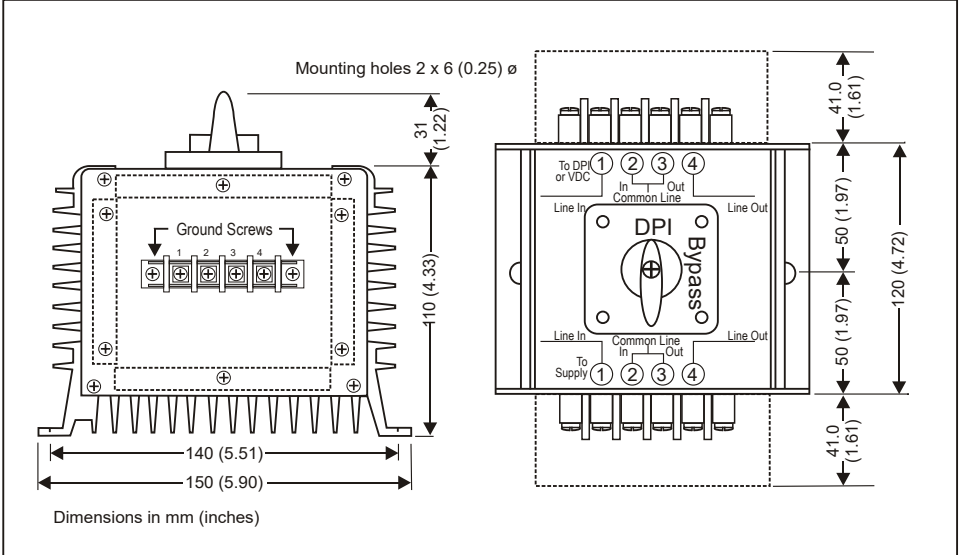

### Ordering

Stock No: 5003 -006 Housed By-Pass Switch 25A

# Voltage Dip-Proofing Inverter

## DPI54S / 54L Series Models 120V & 208/230 50/60Hz

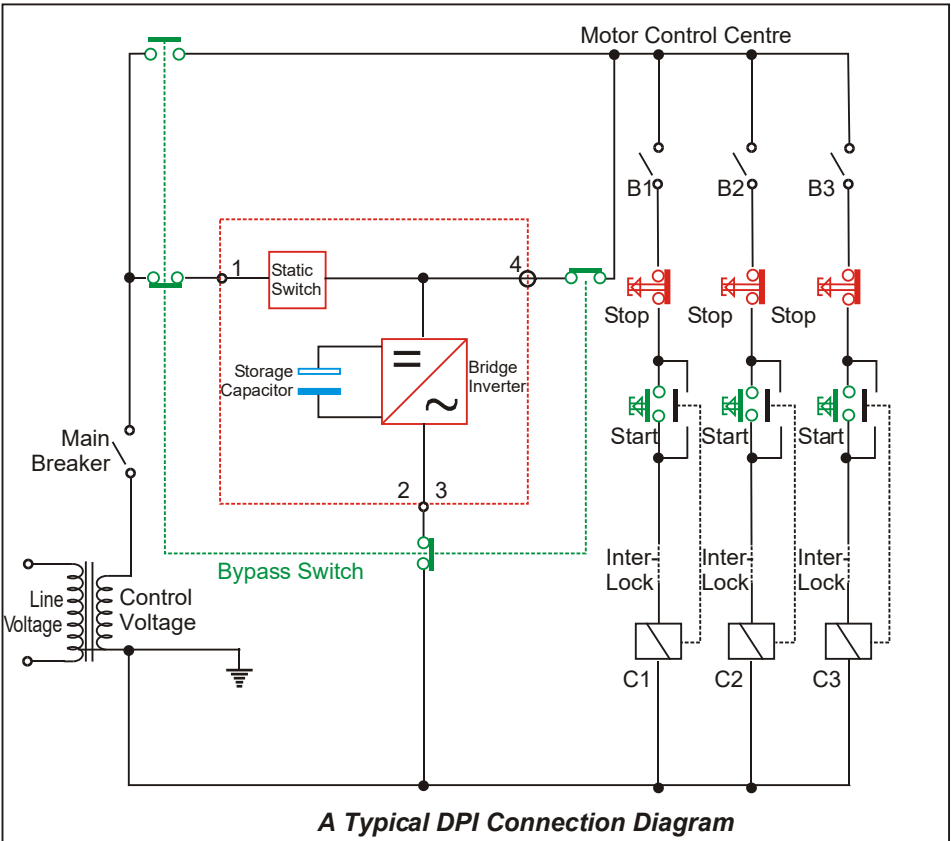

**DIP-PROOFING**  
**TECHNOLOGIES INC.**  
LEADERS IN VOLTAGE-DIP PROOFING

**Measurlogic Inc.**  
7268 S. Tucson Way  
Centennial, CO 80112, USA  
Tel: 1-877-777-6567 Fax: 425-799-4780  
Email: [info@measurlogic.com](mailto:info@measurlogic.com)  
web: [www.measurlogic.com](http://www.measurlogic.com)