

## Using Multiple CT Sets with DTS Meters

### Revision R21B

#### TABLE OF CONTENTS

1	SCOPE .....	2
1.1	IDENTIFICATION.....	2
1.2	INTRODUCTION .....	2
2	USING MULTIPLE CT SETS ON EACH DTS CURRENT INPUT .....	3
2.1	333mV CTs .....	3
2.1.1	Using Multiple Sets of 333mV CTs with a DTS SMX .....	4
2.1.1.1	Using the current terminal connections. ....	4
2.1.1.2	Using the optional 333mV CT daughter board (CPCC-0072 ML) .....	4
2.2	Rogowski Coil CTs.....	5
2.2.1	Joining the Series In-Line wire connection .....	6
2.2.2	Using Multiple Sets of Rogowski Coil CTs with a DTS SMX .....	7
2.2.2.1	Using a Heat Shrink Tube Insulated Solder Wire Joint .....	7
2.2.2.2	Using a WACO 221-412 Lever Nut .....	7
3	USING MULTIPLE CT TO SUBTRACT AN INDIVIDUAL LOAD FROM A TOTAL .....	8
3.1	Wiring Connection and CT Orientation Instructions: .....	8

## 1 SCOPE

### 1.1 IDENTIFICATION

This document describes the guidelines for using multiple 333mV and Rogowski Coil CTs on each phase of a DTS meter.

### 1.2 INTRODUCTION

Normally the current input for each phase of a DTS meter would be connected to one CT only, which is measuring the current in the conductor for that phase.

In some situations, it is useful to connected multiple CTs to each current input of a DTS meter:

- The feed to different loads needs to be combined, but it is not convenient to run all the conductors for the different loads through the aperture of a single CT, due to the positioning of the different breakers or path of the wiring (see section 2).
- This method can also be used to subtract loads from a main feed (see section 3).

The method of using multiple CTs differs depending on the type of the CT. This document discussed how the following CT types are handled:

- 333mV CT
- Rogowski Coil CT



#### NOTE

When using multiple sets of CTs on each input to the DTS meter it is EXTREMELY important that the CTs are connected in the **intended direction**, and on the conductor phase which is the same as the voltage phase that is being measured.

**Any incorrect CT installation will be exceedingly difficult to troubleshoot later.**

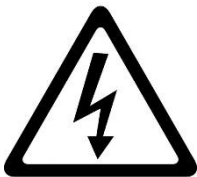

#### WARNING

**This document does not discuss using multiple 5A output CTs.**

*If you have an application that would need multiple 5A output CTs please contact Measurlogic to discuss the project.*

## 2 USING MULTIPLE CT SETS ON EACH DTS CURRENT INPUT

The Measurlogic DTS series of meters allow for ease and flexibility when monitoring multiple branches as a **Total Load**. Any DTS meter with a 333mV input allows multiple CT sensors to be connected in parallel at the current terminals of the meter.

### 2.1 333mV CTs

Please see our website for more information about the Measurlogic range of 333mV CTs:  
<https://www.measurlogic.com/product/mlg-wct-series/>

When using **333mV CT sensors**, the following guidelines **must** be followed exactly to ensure accurate measurements:

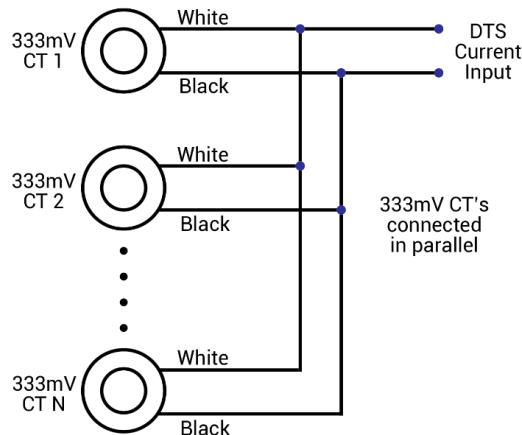

- All CT sensors **must have a 333mV output**.
- All CT sensors must be the **same manufacturer/model number** and **current rating**.
- A full set of 333mV CT sensors must be used for each load.
- The pair of wires from each 333mV CT sensor to the screw terminals must be twisted.
- All 333mV CT sensors for each input must be connected in **PARALLEL**.
- The measured phase current will be the total current for all the loads on that phase.
- The CT primary rating for the DTS meter must be set to the **CT rating \* Number of CT sets**.
- The example below shows the calculation for 2 sets of 100A CTs.

Number of CT Sensor Sets	2 Sets
CT Rating of each CT	100A
CT Primary as set in Meter	2 x 100A = 200A

*Due to the added complexity of the wiring and ensuring that the polarization of all the CTs is correct, Measurlogic do not recommend that more than 3 sets of CTs is used on any meter. If you have an application that would need more than 3 sets of CTs, please contact Measurlogic for guidance.*

## 2.1.1 Using Multiple Sets of 333mV CTs with a DTS SMX

### 2.1.1.1 Using the current terminal connections.

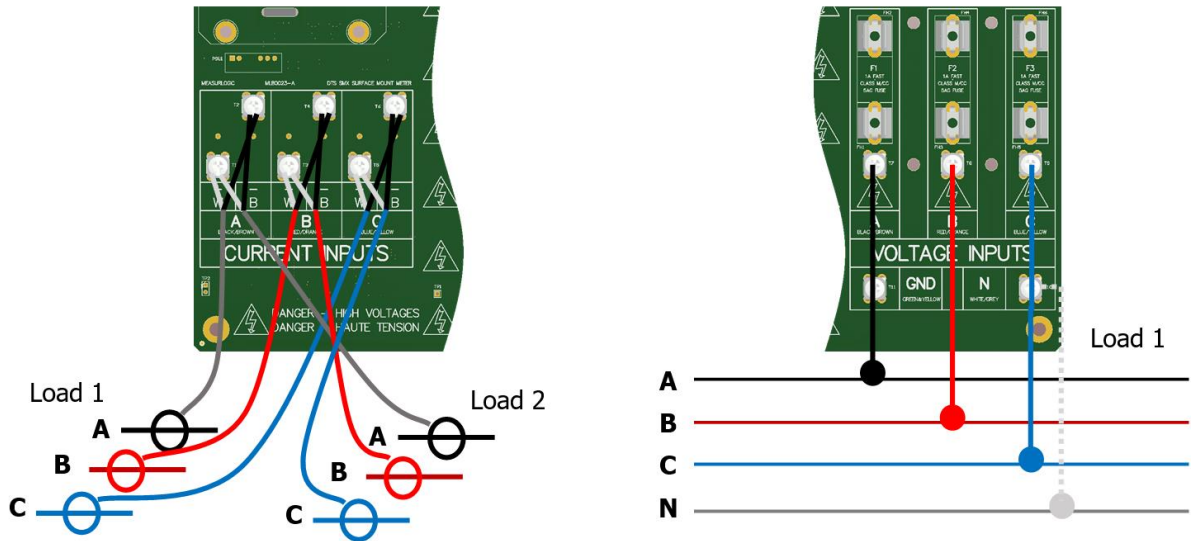

### 2.1.1.2 Using the optional 333mV CT daughter board (CPCC-0072 ML)

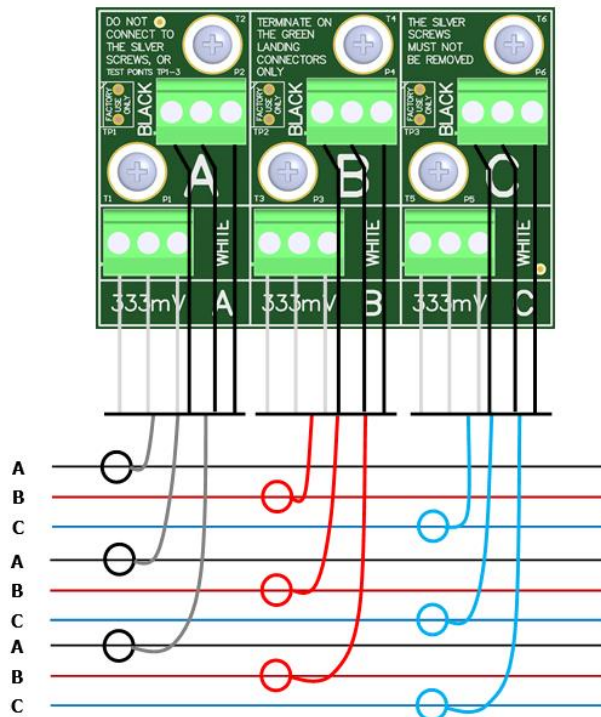

## 2.2 Rogowski Coil CTs

Please see our website for more information about the Measurlogic range of Rogowski Coil CTs:  
<https://www.measurlogic.com/product/mlg-wrt-flexible-rogowski-cts/>

When using **multiple Rogowski Coil CT sensors**, the following guidelines **must** be followed exactly to ensure accurate measurements:

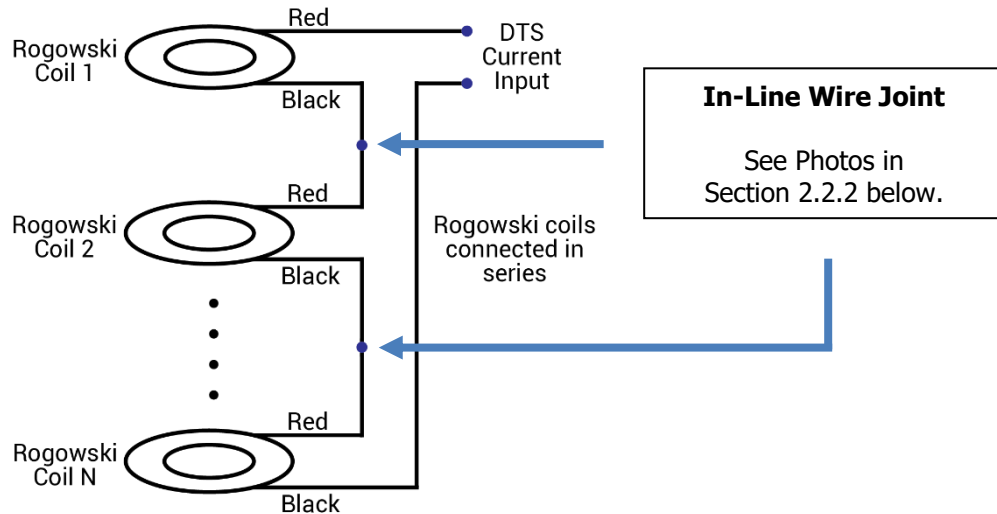

- All Rogowski Coil CT sensors **must have the same sensitivity (mV per 1000A at 60Hz)**.
- All Rogowski Coil CT sensors must be the **same manufacturer** and **model number**.
- A full set of Rogowski Coil CT sensors must be used for each load.
- The pair of wires from each CT sensor to the screw terminals must be twisted and/or shielded.
- Some Rogowski Coil CT may have **WHITE/BLACK** wires instead of **RED/BLACK** wires.
- All Rogowski Coil CT sensors for each input must be connected in **SERIES** as shown below, so that the voltage outputs from each CT in the set are added.
- The measured phase current will be the total current for all the loads on that phase.
- The Rogowski Coil sensitivity in the DTS meter must be set to be the same as the sensitivity of the Rogowski Coils used (No multiplier is used).
- Since the Rogowski Coils are connected in series there will be an in-line **red/black** or **white/black** wire joint of the CT wires, which **MUST NOT** be connected to a screw terminal on the DTS meter. This in-line wire joint must have a good electrical connection and be properly insulated. Please see Section 2.2.1 below for acceptable ways to do this.

*Due to the added complexity of the wiring and ensuring that the polarization of all the CTs is correct, Measurlogic do not recommend that more than 3 sets of CTs is used on any meter. If you have an application that would need more than 3 sets of CTs, please contact Measurlogic for guidance.*

## 2.2.1 Joining the Series In-Line wire connection

The in-line wire joint at the series connection of two Rogowski Coil CTs must have a good electrical connection and be properly insulated.

- The best means of connecting these wires together is by soldering them together and insulating the joint with heat shrink tubing.



- Alternatively, the [Wago 221 Series of Lever Nuts](#) may be used. **WAGO Item no. 221-412** is the 2-way version of this part.



- **Do NOT use conventional electrical contractor wire nuts** to connect the wires – This will result in an unreliable connection because the gauge of the Rogowski Coil wires is too small.



## 2.2.2 Using Multiple Sets of Rogowski Coil CTs with a DTS SMX

### 2.2.2.1 Using a Heat Shrink Tube Insulated Solder Wire Joint

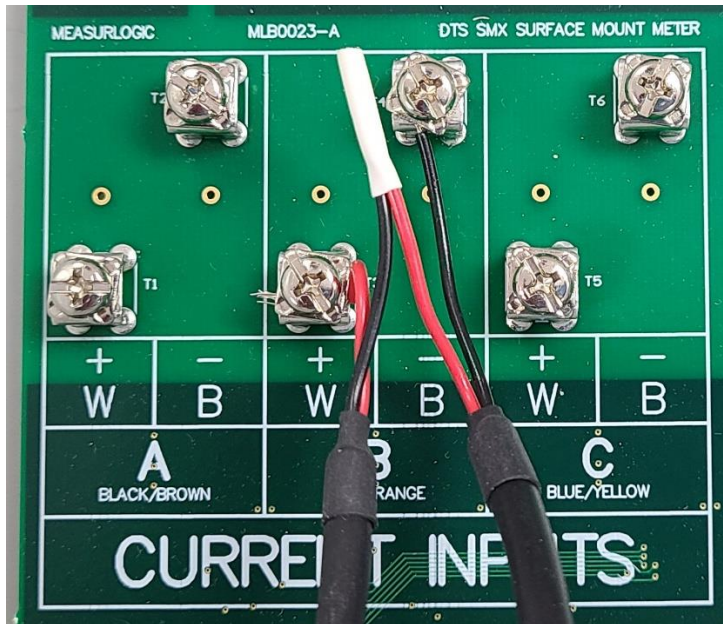

### 2.2.2.2 Using a WACO 221-412 Lever Nut

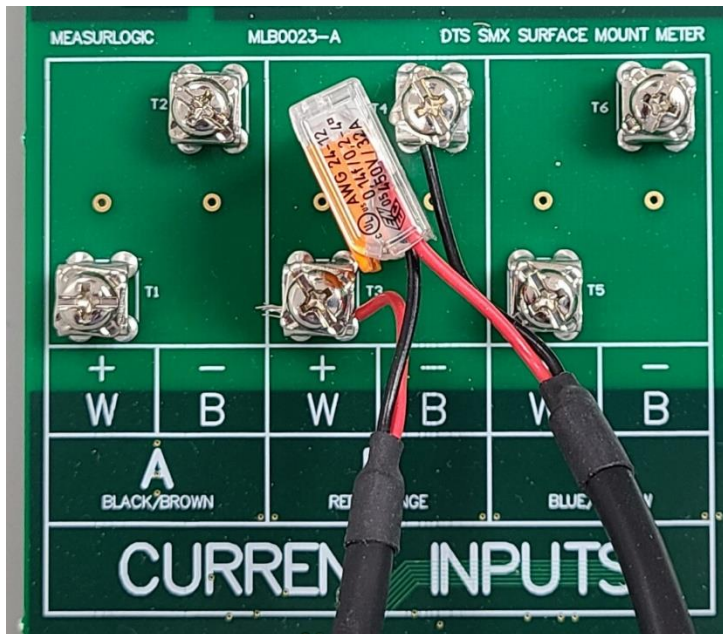

### 3 USING MULTIPLE CT TO SUBTRACT AN INDIVIDUAL LOAD FROM A TOTAL

There may also be cases where it is convenient to measure the feed to the complete panel, but the feed to a sub-panel needs to be excluded (subtracted from the total).

- In this case, the CTs on the conductors for any load that must be subtracted must be installed in the opposite direction to the load. This will effectively subtract the current in the conductors for that load.
- This can be done for either 333mV or Rogowski Coil CTs

#### 3.1 Wiring Connection and CT Orientation Instructions:

1. Connect all the wires for the CT sets to the DTS meter with the **same additive polarity** exactly as shown in the instructions in Section 2.1 (for 333mV CTs) or Section 2.2 (for Rogowski Coils) above.
2. On any feed that needs to be **SUBTRACTED**, install the CTs on the conductors for that feed in the **OPPOSITE** direction to the load current. Depending on the markings on the CT:
  - The LOAD arrow must be pointing to the SOURCE.
  - The side of the CT marked SOURCE must be towards the LOAD.
3. *Measurlogic strongly recommend that where the set of CTs has been installed in this way, that each CT be **clearly labeled** "This feed is being subtracted" (or similar), so that anyone working on the system in the future will know that the CTs were intentionally installed backwards.*

#### Example:

Let us assume that you have a main panel that is being monitored and a sub-panel that needs to be subtracted from the total measurement.

- Install the **CTs for the main panel** in the direction towards the **breakers** in the **main panel**.
  - These CTs will be measuring the entire load to the main panel (including the sub-panel).
- Install the **CTs on the feed to the sub-panel** so that they point towards the **breakers** in the **main panel** (i.e. in the opposite direction to the current flow to the sub-panel).
  - These CTs will subtract the sub-panel load from the main panel total.

*Using the DTS meters and CTs in this way adds even more complexity to the system. Measurlogic strongly recommends that you contact us for guidance for such systems.*