

DTS 307 Ethernet

DIN – Rail Mounted, Ultra-Compact Revenue Grade Electrical Sub-meter



1	PRODUCT OVERVIEW	3
1.1	SUPPLIED ITEMS	4
1.2	DOCUMENT CONVENTIONS	4
1.3	PRODUCT SPECIFICATION	5
1.3.1	<i>Current Inputs</i>	5
1.3.2	<i>Service Type</i>	5
2	INSTALLATION	6
2.1	ENVIRONMENT.....	6
2.2	SAFETY GUIDELINES	6
2.3	PRODUCT DIMENSIONS.....	7
2.4	PRODUCT LABELING	7
2.5	GENERAL MOUNTING REQUIREMENTS AND GUIDELINES	8
2.6	MOUNTING THE DTS 307 IN AN ELECTRICAL PANELBOARD	10
2.7	STANDALONE MOUNTING OF THE DTS 307	11
3	CONNECTING TO THE DTS 307	12
3.1	PLUGGABLE GREEN TERMINALS.....	12
3.2	CURRENT TRANSFORMER WIRING COLORS AND CONNECTION POLARITY	13
3.3	WIRING VOLTAGE AND CURRENT INPUTS	14
3.3.1	<i>Wiring Examples</i>	14
3.4	CONFIGURING THE CURRENT SENSOR TYPE AND RATED CURRENT OF THE CT	15
3.4.1	<i>Configuring the Electrical Settings using the Embedded Web Pages</i>	16
3.4.2	<i>Configuring the Electrical Settings using DTS Config</i>	17
3.4.3	<i>Details for the Electrical Settings</i>	18
3.5	CONNECTING MULTIPLE LOADS.....	19
3.6	DTS 307 COMMUNICATIONS INTERFACE.....	19
3.7	ETHERNET	20
3.7.1	<i>Ethernet Connection and Configuration</i>	20
3.8	KWH PULSE OUTPUT (MODEL DEPENDENT)	21
4	LED DEFINITIONS	21
4.1	STATUS LED	21
5	INSTALLATION OF DTS DISCOVER & DTS CONFIG	22
6	MAINTENANCE AND SERVICE	22
6.1	CLEANING INSTRUCTIONS	22

1 PRODUCT OVERVIEW

The One Revenue Grade Meter for all Applications.

Our DTS 307 Ethernet energy sub-meter is one of the most versatile meters available on the market.

The standard DTS 307 is a full 3-Phase measurement RGM. It is also capable of being used to monitor a single phase 3-wire load panel and the production from an inverter system using the same meter.

The DTS 307 can operate in any environment, requires no external power source to operate, and works with all UL or ETL listed 333mV or Rogowski current transformers.

For ease of installation, the DTS 307 is designed to be ultra-compact and fit into most DIN-rail systems.

Some of the exciting features provided with the DTS 307 are:

- Easy to attach pluggable terminals.
- Modbus TCP or BACnet/IP depending on model.
- Auto-topology Phase Detection.
- Automatic correction of reversed field mounted CTs.

For remote configurability, your DTS 307 comes with our freely downloadable *DTS Config* software tool.

The DTS 307 is certified to ANSI C12.20 Class 0.5 Revenue Grade.

Also, if in the future, you decide to integrate renewable energy sources, the DTS 307 will conveniently operate as a Bi-Directional **NET** meter. Easily integrates with Building Automation Systems and Energy Monitoring Software.

Designed and Manufactured in the USA and complies with the Buy American Provisions of ARRA Section 1605.

Thank you for choosing Measurlogic and a meter from the DTS Family.

1.1 Supplied Items

Check that the meter and equipment match your order specifications and has not been damaged during shipping. Verify that the following item(s) match with the corresponding model from the data sheet:

- Installation Guide
- DTS 307 power & energy meter
- 7-Pin green pluggable screw terminal connector for Voltage Inputs
- 2-Pin green pluggable screw terminal connector for Digital Output
- 6-Pin green pluggable screw terminal connector for Current inputs

1.2 Document Conventions

SYMBOLS



ATTENTION	ATTENTION
This section contains information that is important to the operation of the meter.	Cette section contient des informations importantes pour le fonctionnement du compteur.



WARNING	AVERTISSEMENT
This section contains very important safety information to reduce the risk of electrical shock.	Cette section contient des informations de sécurité très importantes pour réduire le risque de choc électrique.

1.3 Product Specification

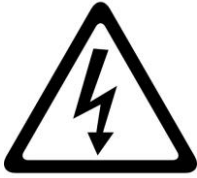

WARNING	AVERTISSEMENT
<p>Measurement Category III</p> <p>DTS 307 is intended for 208Vac to 480Vac L-L use</p> <p>Do NOT exceed this usage</p>	<p>Catégorie de mesure III</p> <p>Le DTS 307 est destiné à une utilisation 208Vac à 480Vac L-L</p> <p>Ne dépassez PAS cette utilisation</p>
<p>Use the model number of the DTS 307 to verify that it is suitable for the voltage, type and category of the installation.</p>	<p>Utilisez le numéro de modèle du DTS 307 pour vérifier qu'il convient à la tension, au type et à la catégorie de l'installation.</p>
<p>Failure to use the correct current transformers, and/or connecting too high a voltage can result in death or personal injury and may permanently damage the DTS meter.</p>	<p>Le fait de ne pas utiliser les transformateurs de courant corrects et/ou de connecter une tension trop élevée peut entraîner la mort ou des blessures corporelles et peut endommager de manière permanente le compteur DTS.</p>

The model number for the normal three-phase DTS 307 is:

DTS 307 - Ax-Ex-x-F

1.3.1 Current Inputs

Current Inputs	Value	Description	Notes
A	3	333mV Split/Solid Core or Rogowski Coil CT	The choice between 333mV or Rogowski Coil CTs is software selectable. All three channels must be the same CT type. The Rogowski Coil input sensitivity is also software selectable.

1.3.2 Service Type

Service Type	Value	Description	Neutral Required	Neutral Optional
F	N	(1P 2W, 1P 3W, 3P 4W) 120 – 277Vac L– N	•	

2 INSTALLATION

2.1 Environment

Operating Temperature:	-31°F to 158°F	(-35°C to 70°C)
Storage Temperature:	-40°F to 185°F	(-40°C to 85°C)
Relative Humidity:	5% to 95%	(non-condensing)
Operating Altitude:	Up to 3,000m	

2.2 Safety Guidelines

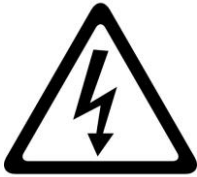

WARNING	AVERTISSEMENT
<p>To reduce the risk of electric shock, always open or disconnect circuit from power-distribution system (or service) of building before installing or servicing submetering equipment or current sensors.</p>	<p>Pour réduire le risque de choc électrique, toujours ouvrir ou débrancher le circuit du système de distribution d'énergie (ou service) du bâtiment avant installer ou entretenir des équipements de sous-comptage ou des capteurs de courant.</p>

Always adhere to the following safety guidelines:

- Only qualified personnel or **licensed electricians** should handle the installation. Input voltages to the DTS 307 can be hazardous.
- Follow all applicable local and national electric codes.
- Verify input voltage and current are within thresholds for the specific DTS 307 model. (See Product Specification on page 5)
- **Only Current Transformers that are listed to UL 2808 for use in 250Vac or 600Vac line-to-line circuits (as appropriate for the installation) may be used with this meter.**
- **ONLY USE CURRENT TRANSFORMERS WITH OUTPUTS THAT ARE COMPATIBLE WITH THE MODEL OF DTS 307 (SEE SECTION 1.3.1). THE USE OF ANY OTHER CURRENT TRANSFORMER CAN RESULT IN PERMANENT DAMAGE TO THE DTS 307.**
- Avoid any electrostatic discharge prior to working on the DTS 307 by first touching a grounded structure prior to handling the DTS 307.
- Before applying power make sure that all current transformer and voltage connections are securely connected to the input terminals of the DTS 307.
- If the DTS 307 is installed incorrectly any built-in safety features may no longer be functional.
- Before handling the DTS 307 ensure that all power running to the DTS 307 is removed.
- The DTS 307 MUST be mounted in a NEC compliant enclosure suitable for the application's environmental conditions.

- The DTS 307 may be used outdoors if housed in an outdoor rated enclosure that prevents water ingress, such as a NEMA Type 3R / IP14 or higher that is suitably rated for the application.
- The enclosure must be equipped with a **user supplied lock** or other means to prevent unauthorized access.

2.3 Product Dimensions

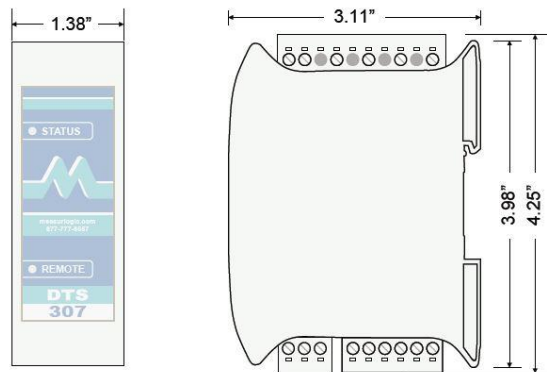

2.4 Product Labeling

The blue side label on the DTS 307 meter contains important information:

- The connections for the meter. These are covered in more detail later in this document.
- The white information window on the label details the type of "REMOTE" interface and the available protocols, as well as other important details about the voltage and current inputs of the meter.

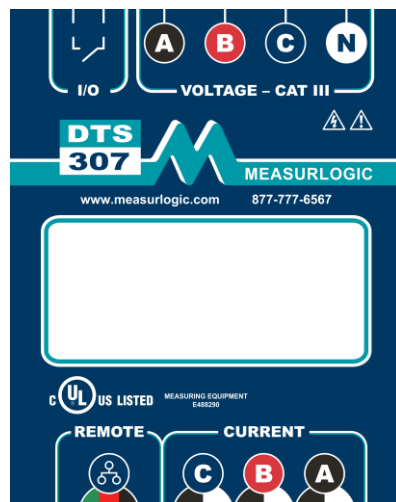

2.5 General Mounting Requirements and Guidelines

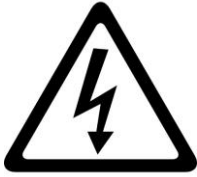

WARNING	AVERTISSEMENT
<p>To reduce the risk of electric shock, always open or disconnect circuit from power-distribution system (or service) of building before installing or servicing submetering equipment or current sensors.</p>	<p>Pour réduire le risque de choc électrique, toujours ouvrir ou débrancher le circuit du système de distribution d'énergie (ou service) du bâtiment avant installer ou entretenir des équipements de sous-comptage ou des capteurs de courant.</p>

When mounting the DTS 307 make sure to follow these guidelines:

- Always completely de-energize the electrical panelboard, switchboard, industrial control equipment and/or energy monitoring management equipment before installing or servicing the DTS 307 meter and/or its Current Transformers.
- See section 2.2 above for further safety information.
- Make sure that there is sufficient clearance above and below the DTS 307 for wiring and connector clearance.
- Position the DTS 307 such that the labeling can be read from the upright position.
- Only UL or ETL rated conduits and glands should be used.
- It is recommended that two separate conduits be run for voltage conductors and current sensors leads.
- Use Copper Conductors ONLY.
- Only Current Transformers that are listed to UL 2808 for use in 250Vac or 600Vac line-to-line circuits (as appropriate for the installation) may be used with this meter.
- The Current Transformers may NOT be installed in equipment where they exceed 75% of the wiring space of any cross-sectional area within the equipment.
- Current Transformer may NOT be installed in areas where they would block ventilation openings.
- Current Transformer may NOT be installed in areas of breaker arc venting.
- Current Transformers must be secured, and their conductors routed so that they do not directly contact live terminals or buses.
- DTS 307 meters that have an "A" in the Service Type field of the model number (as shown in section 1.3.2) are powered through the 24Vac/dc auxiliary terminals. An external IEC 60950 compliant Class 2 isolated power supply and associated wiring methods must be used for this powering option only. Please see Section 3.6 for further details.

- **User Supplied** UL or ETL certified 2A fast-blow fuses need to be installed between the Voltage inputs of the DTS 307 and the panel being monitored. Recommended Littelfuse BLS002 or equivalent. The Measurlogic inline fuse kit can be used for this purpose. (See the Measurlogic webpage at <https://www.measurlogic.com/product/inline-fuse-kit/> for details).
- A UL or ETL certified 600V circuit-breaker must be installed as a disconnecting device for the DTS 307 and must be positioned within easy reach of the DTS 307. The circuit-breaker employed for this disconnecting device shall meet the relevant requirements of IEC 60947-1 and IEC 60947-3, be suitable for the application, and **MUST** be clearly marked as being **"the disconnecting device"** for the DTS 307. See table below for the wire gauge to use for the breaker rating.

WIRE & BREAKER GUIDE	
Gauge of Wire	Recommended Breaker
18 AWG	5 Amp 600V 3-Pole Breaker
14 AWG	15 Amp 600V 3-Pole Breaker
12 AWG	20 Amp 600V 3-Pole Breaker

2.6 Mounting the DTS 307 in an Electrical Panelboard.

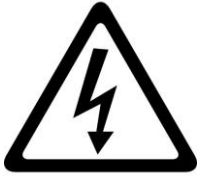

WARNING	AVERTISSEMENT
<p>To reduce the risk of electric shock, always open or disconnect circuit from power-distribution system (or service) of building before installing or servicing submetering equipment or current sensors.</p>	<p>Pour réduire le risque de choc électrique, toujours ouvrir ou débrancher le circuit du système de distribution d'énergie (ou service) du bâtiment avant installer ou entretenir des équipements de sous-comptage ou des capteurs de courant.</p>

The DTS 307 is UL 2808-2020 certified to be mounted inside an electrical panelboard, switchboard, industrial control equipment and/or energy monitoring management equipment.

The following applies when mounting a DTS 307 inside any type of Electrical Panelboard:

- All the requirements and guidelines outlined in Section 2.5 above apply in addition to those below.
- The submetering equipment shall NOT be mounted within 50.8 mm (2 in) of any live parts including primary conductors, primary terminals, primary lugs. This requirement excludes insulated cables.
- Submeters attached to the enclosure shall NOT contact the panel interior insulation.
- Mounting provisions shall NOT be attached to any live part.
- Voltage sensing and power supply connections to the primary voltage shall have overcurrent protection.
- Do not install submetering equipment in any area where breaker arc venting exhaust gasses could be re-directed as a result of submetering equipment installation.
- The DTS 307 meter may NOT be installed in equipment where it exceeds 75% of the wiring space of any cross-sectional area within the equipment.
- If possible, the DTS 307 should be securely fastened in the electrical panelboard, switchboard, industrial control equipment and/or energy monitoring management equipment. The Measurlogic right angle DIN rail bracket CHWR-0200A can be used to mount the DTS 307 meter (See the Measurlogic webpage at <https://www.measurlogic.com/product/right-angle-mounting-bracket/> for details).

2.7 Standalone Mounting of the DTS 307.

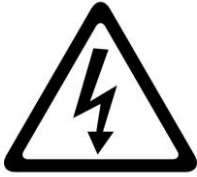

WARNING	AVERTISSEMENT
<p>To reduce the risk of electric shock, always open or disconnect circuit from power-distribution system (or service) of building before installing or servicing submetering equipment or current sensors.</p>	<p>Pour réduire le risque de choc électrique, toujours ouvrir ou débrancher le circuit du système de distribution d'énergie (ou service) du bâtiment avant installer ou entretenir des équipements de sous-comptage ou des capteurs de courant.</p>

The following applies when mounting a DTS 307 in a standalone application:

- All the requirements and guidelines outlined in Section 2.5 above apply in addition to those below.
- The DTS 307 must be mounted in an enclosure that is appropriately rated for environmental conditions where it is mounted.
- Mount the enclosure containing the DTS 307 as close as possible to the electrical panel being monitored, so that it is within easy reach of the electrical disconnect breaker.
- The DTS 307 may be used outdoors if housed in an outdoor rated enclosure that prevents water ingress, such as a NEMA Type 3R / IP14 or higher that is suitably rated for the application.

3 CONNECTING TO THE DTS 307

3.1 Pluggable Green Terminals

Pluggable green terminals are provided with your DTS 307 meter for external connections to the meter. These include the connections for the voltage inputs, current transformer inputs, RS-485 communications and the pulse output/aux input. The blue label on the side of the DTS 307 shows the allocation of these connections on the various plug terminals.

Green Terminal Plugs	Value
Wire Gauge Range	24 to 12 AWG
Wire Stripping Length	7mm to 8mm (about 0.3")
Torque Value	0.5 N m (4.43 lb in)
Suitable Screwdriver	3.0mm or 3.5mm flat head

The stripped ends of the wires can be fitted directly into the terminal cages of the green terminals plugs. If you would prefer to use ferrules for multi-strand wires, here is a list of ferrule parts to suit the various wire sizes.

	Ferrules			
	AWG	Color	ElecDirect *	DigiKey *
Voltage 20A CB	12	-	-	-
Voltage 15A CB	14	Blue	FER-14-8D	288-1024-ND
333mV CTs	18-22	Red	FER-18-8D	288-1015-ND
Rogowski CTs	24	Yellow	FER-24-8D	288-1004-ND
Pulse, Comms, Aux	18-22	Red	FER-18-8D	288-1015-ND

* For convenience, part numbers and links are provided for ElectDirect and DigiKey but any equivalent part is acceptable.

3.2 Current Transformer Wiring Colors and Connection Polarity

The built-in wires from Current Transformers may have different colors depending on the type and manufacturer. However, the wire representing the **negative (-)** lead is always **black**.

When connecting a CT to the DTS meter, please land the **black wire** on the **black (-) side** of the current input pair on the meter, and land the **other color** wire (**white, red** or other color) on the **white (+) side** on the meter.

The pictures below show the wire colors for the Measurlogic series of Split and Solid Core CTs and the Measurlogic series of Rogowski Coil CTs. Please contact Measurlogic if you are unsure about the CT connection wiring.

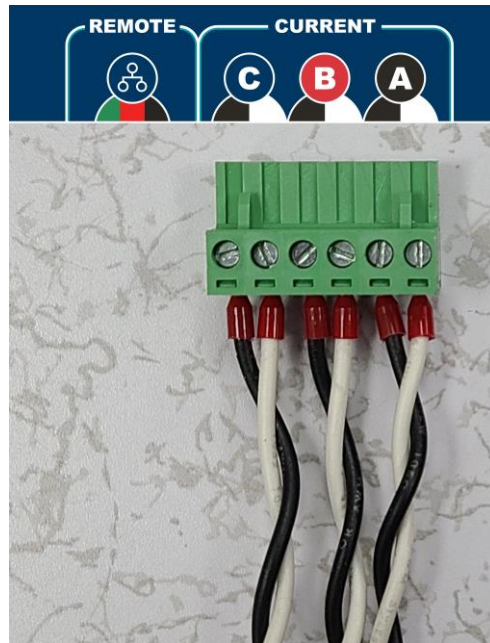

Split and Solid Core CTs

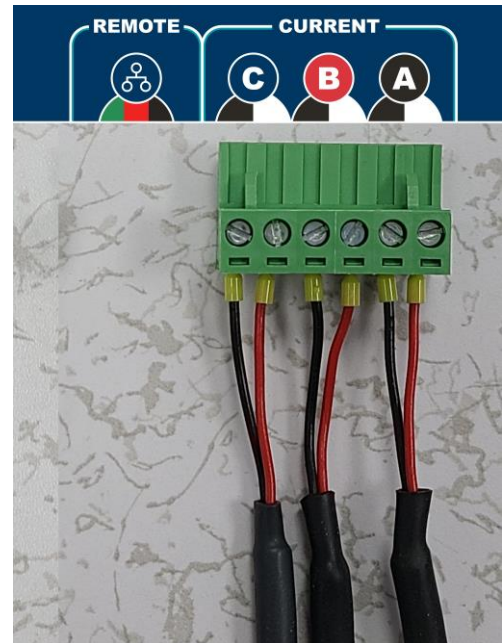

Rogowski Coil CTs



ATTENTION	ATTENTION
<p>The current transformer connections are shown on the label as black/white, which is common for the twisted pair wire for split and solid core CTs.</p> <p>The Measurlogic Rogowski Coil CTs have black/red wires.</p> <p>If the color of the wires is different to black/white then land the black wire on the black side, and the other color on the white side on the meter.</p>	<p>Les connexions du transformateur de courant sont indiquées sur l'étiquette par un fil noir/blanc, ce qui est courant pour les paires torsadées des transformateurs de courant à noyau fendu et massif.</p> <p>Les transformateurs de courant à bobine Rogowski de Measurlogic possèdent des fils noir/rouge.</p> <p>Si la couleur des fils est différente de noir/blanc, connectez le fil noir à la borne noire et l'autre couleur à la borne blanche du multimètre.</p>

3.3 Wiring Voltage and Current Inputs



ATTENTION	ATTENTION
Examine the model number of each of your meters to ensure that they are suitable for the type and voltage of the service you are connecting to. See section 1.3 for details.	Examinez le numéro de modèle de chacun de vos compteurs pour vous assurer qu'ils conviennent au type et à la tension du service auquel vous vous connectez. Voir rubrique 1.3. pour plus de détails.
Current transformers should be connected to the same panel as the voltage connections.	Les transformateurs de courant doivent être connectés au même panneau que les connexions de tension.

3.3.1 Wiring Examples

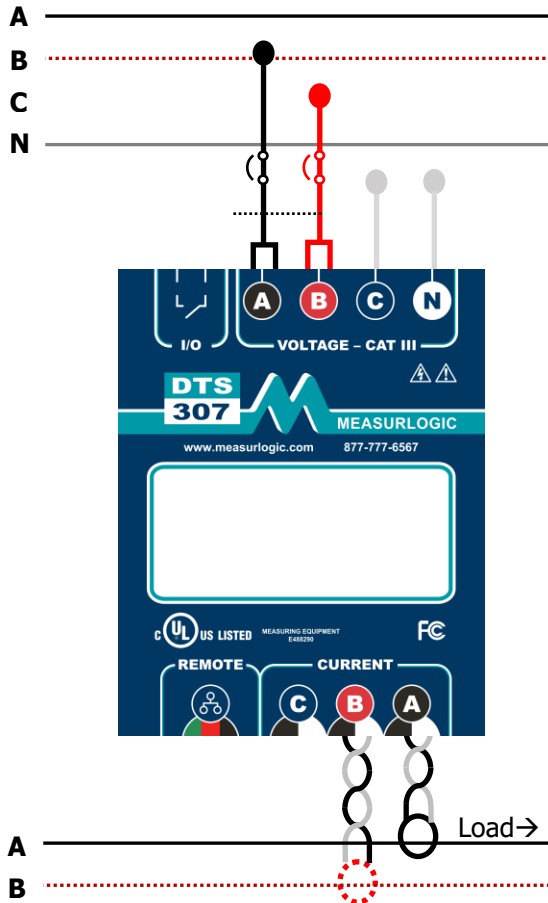

DTS 307
Single Phase 2/3 Wire
Unused Voltage Inputs MUST be
Connected to the Neutral Terminal

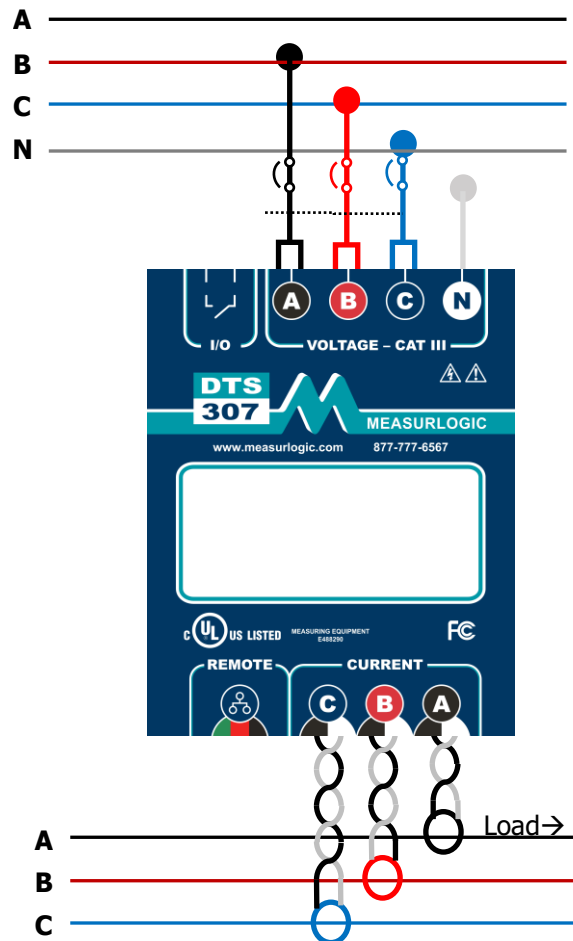

DTS 307
3-Phase 4 Wire
(with Neutral)

3.4 Configuring the Current Sensor Type and Rated Current of the CT



ATTENTION	ATTENTION
The DTS 307 meter only supports 333mV and Rogowski Coil CTs. DO NOT attempt to connect a 5A secondary CT to the DTS 307, as this will result in damage to the DTS 307 and the CT.	Le compteur DTS 307 ne prend en charge que les TC à bobine de 333 mV et Rogowski. N'essayez PAS de connecter un TC secondaire de 5A au DTS 307, car cela entraînerait des dommages au DTS 307 et au TC.

The **DTS 307-3x-Ex-x-x** meters are compatible with the following current sensors **ONLY**:

- 333mV Output CTs** – This type of current sensor is internally burdened so that the voltage output is 333mV for the current rating as specified on the CT itself. The current rating (Amperage) of the CT must be specified when ordering and cannot be changed in the field.
 - Use DTS Config to configure the Current Sensor Type as "333mV".
 - The Rated Current (Amperage) of the CT as it appears on the CT label **MUST** be configured in the DTS 307 Meter.
- Rogowski Coil CTs** – This is a flexible CT. Measurlogic DTS meters can accept Rogowski Coil CTs directly **without** the need for an external integrator. The sensitivity of this type of current sensor is specified in milli-volts (mV) per 1000A at 60Hz. Different models of Rogowski Coils have different sensitivities, which must be selected from the pull-down menus in DTS Config and set accordingly. The CT Rating (Amperage) that is set does not affect the current measurement values. We recommend that you set the CT Rating in the meter to the panel rating, or the expected nominal current being measured.
- Rogowski Coil CTs (with an external integrator)** – Measurlogic DTS meters can accept Rogowski Coil CTs directly connected to the DTS 307 meter, so an external integrator module is NOT required. However, if the system already has an external integrator module installed, then the output of the integrator will be 333mV for the current specified on the integrator label. For such systems, the DTS 307 meter must be configured for a "333mV" input. The Rated Current (Amperage) as it appears on the integrator label **MUST** be configured in the DTS 307 Meter.

NOTE

If multiple CTs per phase are required, please see section 3.5 below for a 333mV CT example. Our document "**Using Multiple CT Sets with DTS Meters**" in the "Technical" section of the DTS 307 webpage at <https://www.measurlogic.com/product/dts-307/> contains more detailed information regarding multiple 333mV and Rogowski Coil CT applications.

3.4.1 Configuring the Electrical Settings using the Embedded Web Pages

Select "Electrical Settings" from the left menu on the embedded webpage to show the Current Transformer settings.

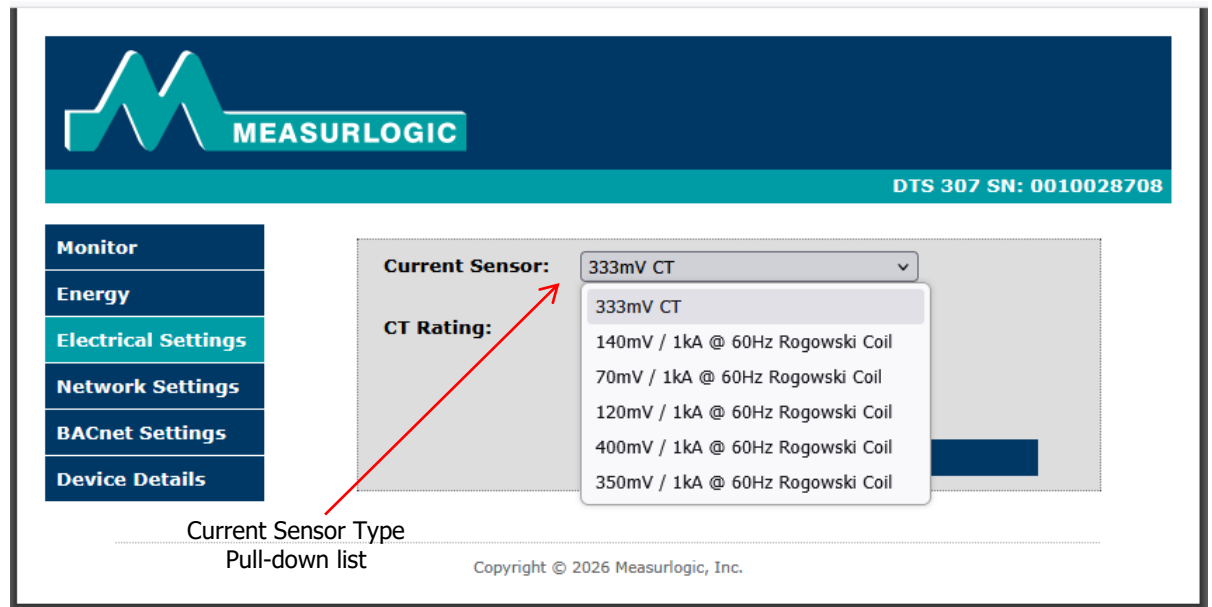
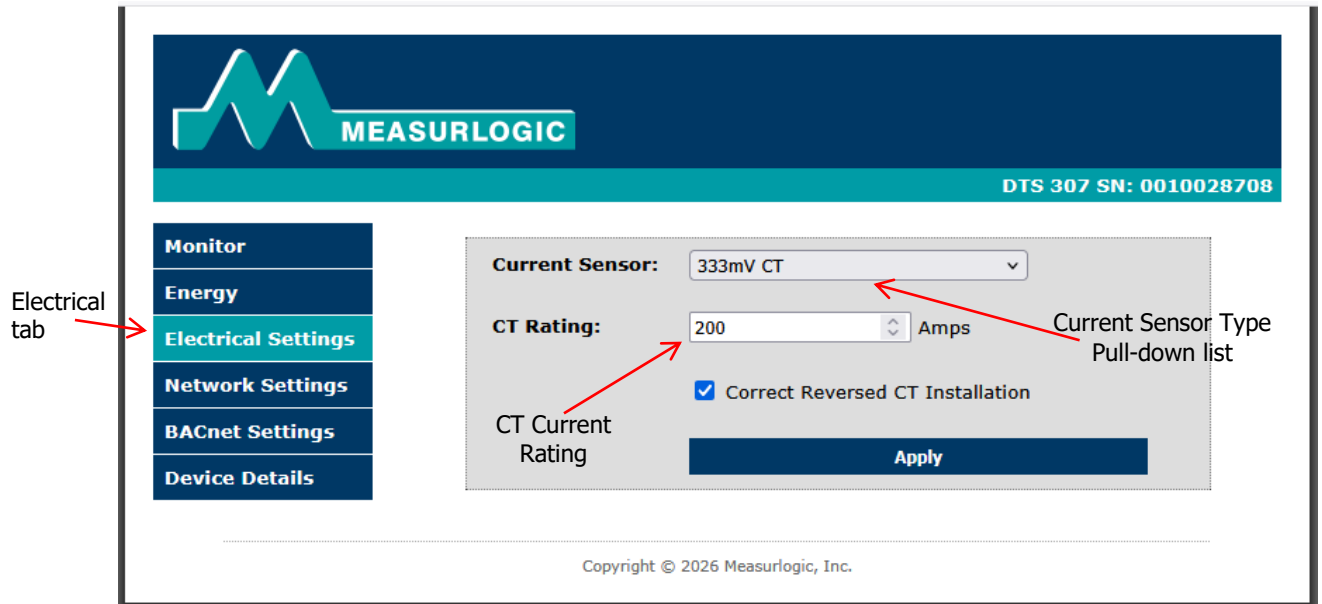

Please see the following Measurlogic [youtube channel](#) videos for more information on the embedded webpages in the Ethernet DTS meter:

- Accessing Embedded Webpages - DTS Meter Network Connectivity: <https://www.youtube.com/watch?v=ckjAoacdZ6o>
- Navigating Embedded Webpages - DTS Meter Network Connectivity: <https://www.youtube.com/watch?v=om70QA8-pdo>

3.4.2 Configuring the Electrical Settings using DTS Config

Select "Configure" from the menu. The Current Transformer settings can be found in the "Electrical Settings" tab. The screenshots show the layout of the latest version of DTS Config. The screen layout for previous versions of DTS Config may differ.

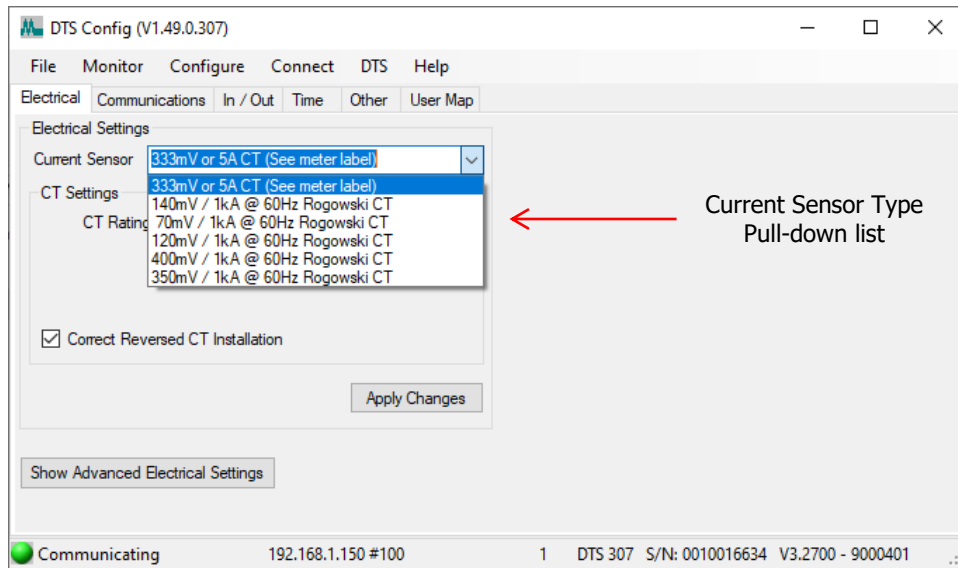
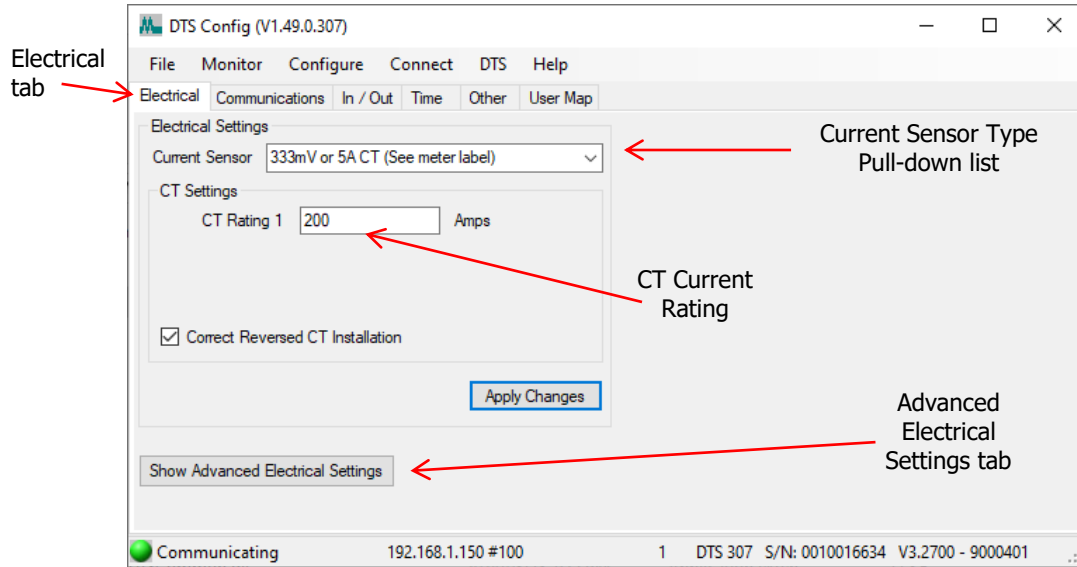

3.4.3 Details for the Electrical Settings

Configuring 333mV output CTs

- Set the CT Rating (Amperage) of the CTs that are being used.
- Ensure that the "Current Sensor" type selected shows "333mV CT".

Configuring Rogowski Coil CTs

- Set the CT Rating (Amperage) to the panel rating, or the expected nominal current being measured. This value does not affect the current measurement values.
- Select a Rogowski Coil output option from the "Current Sensor" drop down list that matches the output of the Rogowski Coils being used, as this directly affects the current measurement values.

Voltage(L-L) Primary and Secondary settings (DTS Config only)

- **Low Voltage Applications:** Do NOT change the Voltage(L-L) Primary and Secondary settings. These two numbers MUST be the same values for correct operation. The ratio must be 1:1.
- **Medium or High Voltage Applications (with external PTs):** The Voltage(L-L) Primary and Secondary settings MUST be set according to the primary and secondary ratings of the external PTs.

3.5 Connecting Multiple Loads

The DTS 307 allows for ease and flexibility when monitoring multiple branches. The DTS 307 allows multiple CT sensors to be connected in parallel via the green pluggable screw terminal.

When using parallel CT sensors, the following guidelines must be followed to ensure accurate measuring.

- All CT sensors must have a 333mV output.
- All CT sensors must be of the same manufacturer/model number and current rating.
- A full set of CT sensors must be used for each load.
- The pair of wires from the CT sensor to the green pluggable screw terminal must be twisted.
- All CT sensors must be terminated at the green pluggable screw terminal.
- The measured phase current will be the total current across all the loads on that phase.
- The CT primary rating for the DTS 307 must be set to the **CT rating * Number of CT sets**.
- The example below shows how to calculate the service current for figure 3.2.1.
- A maximum of 3 loads can be monitored at once (Contact Measurlogic if more than 3 loads must be monitored). Please see the document "[Using Multiple CT Sets with DTS Meters](#)" on the Measurlogic website for more information.

Service Current for Figure 3.2.1	
Number of CT Sensor Sets	2
CT Rating	100 Amps
CT Primary	200 Amps

3.6

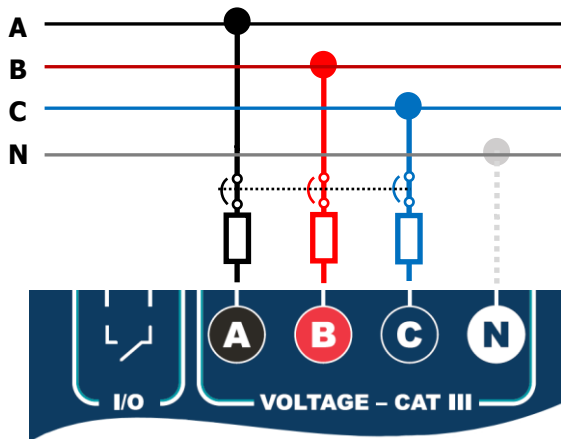
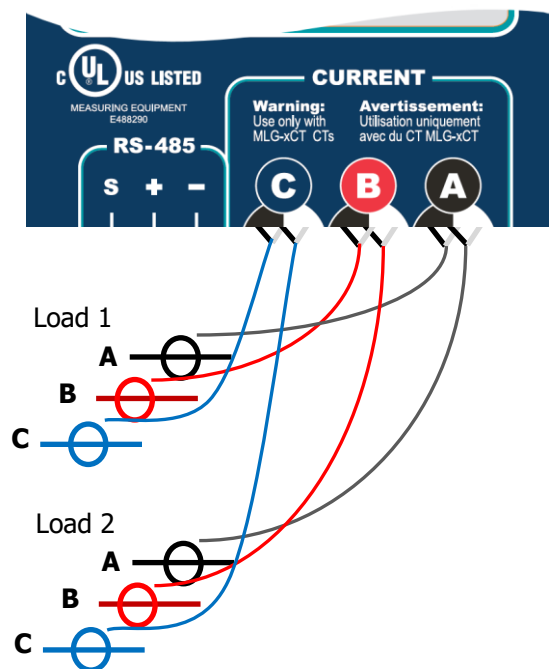
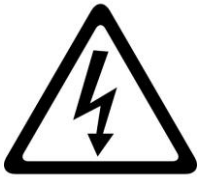

Figure 3.2.1



DTS 307 COMMUNICATIONS INTERFACE



WARNING	AVERTISSEMENT
Ensure that all external devices that are connected to either or both of the Ethernet communications bus, and/or the digital solid state relay output have been certified to be IEC 60950 compliant.	Assurez-vous que tous les périphériques externes connectés à l'un ou l'autre des bus de communication Ethernet et/ou à la sortie de relais numérique à semi-conducteurs ont été certifiés conformes à la norme CEI 60950.

The DTS 307 has 2 options for outputting data **depending on the model ordered**:

- Modbus TCP and BACnet/IP over a 10/100 Base-T Ethernet on the RJ-45 connector.
- A kWh Energy Pulse Output through a Potential-Free Normally Open (N.O.) Solid State Relay (SSR).
Do NOT use this output to switch more than 42Vdc.

3.7 Ethernet

- Use CAT5e or better Ethernet cable that is suitable for the installation location.
- The Ethernet DTS meter can communicate using the **Modbus TCP** and **BACnet/IP** simultaneously.
- Up to 4 Modbus TCP clients can be used at the same time.
- Unless otherwise specified, all new DTS meters now leave the factory with DHCP Client enabled so that the meter can obtain a valid IP Address from the DHCP Server on the local network.
- Please refer to the first youtube video listed below for various methods to find the IP Address allocated to the DTS meter and to access the Embedded Webpages in the DTS meter.
- The IP Address of the DTS meter can be changed to a static IP Address using the Measurlogic [DTS Discover](#) Windows App or by using the embedded webpages in the meter.

3.7.1 Ethernet Connection and Configuration

The Measurlogic [youtube channel](#) hosts some useful instruction videos for finding, connecting to and configuring your Ethernet DTS meter:

- Accessing Embedded Webpages - DTS Meter Network Connectivity: <https://www.youtube.com/watch?v=ckjAoacdZ6o>
- Navigating Embedded Webpages - DTS Meter Network Connectivity: <https://www.youtube.com/watch?v=om70QA8-pdo>
- DTS Discover - DTS Meter Network Connectivity: <https://www.youtube.com/watch?v=xJLadESTqqU>

5 INSTALLATION OF DTS Discover & DTS Config

- **DTS Discover** is a discovery app used to find DTS Ethernet devices on the local network.
- **DTS Config** is a program used to easily monitor and configure meters from the DTS family from your local PC or across the LAN.
- Download the latest version of DTS Discover and DTS Config from the "software" page on the Measurlogic website: <https://www.measurlogic.com/software-drivers/>.
- Unzip the downloaded zip files to a real folder on the hard drive file and double click the **setup.exe** file to begin the installation process. Follow the instructions on the screen.

6 MAINTENANCE AND SERVICE

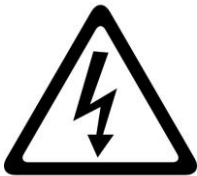

WARNING	AVERTISSEMENT
There are NO other user serviceable parts in the DTS 307, and no regular maintenance is required. If additional maintenance is needed, please contact Measurlogic Inc.	Il n'y a AUCUNE autre pièce réparable par l'utilisateur dans le DTS 307, et aucun entretien régulier n'est requis. Si une maintenance supplémentaire est nécessaire, veuillez contacter Measurlogic Inc.

6.1 Cleaning Instructions

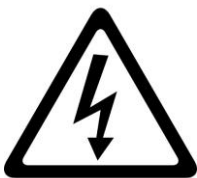

WARNING	AVERTISSEMENT
To reduce the risk of electric shock, always open or disconnect circuit from power-distribution system (or service) of building before installing or servicing submetering equipment or current sensors.	Pour réduire le risque de choc électrique, toujours ouvrir ou débrancher le circuit du système de distribution d'énergie (ou service) du bâtiment avant installer ou entretenir des équipements de sous-comptage ou des capteurs de courant.

Regular cleaning of the DTS 307 is **NOT** required, but if you do wish to clean the DTS 307, please note the following:

- Before attempting to clean the DTS 307 ensure that all power running to the DTS 307 is removed.
- **Use only a slightly damp cloth to clean the outside of the meter only.**
- Do not use any harsh chemicals or detergents.
- No water or any other liquid must be allowed to enter the meter.
- Do not use a spray bottle.